

POWDER FEEDERS

Description

- Powder feeder designed for metering dry additives
- Powder feeders are available in Loss In Weight or Volumetric configurations

Volumetric Features

- 6.7 cubic foot capacity ingredient hopper
- Hinged lid with locking handle, gas springs and prox switch for refill indication
- Bolted in expanded metal trash screen
- Feeder screw sized to your rate needs
- 1-1/2 hp feeder screw gearmotor drive
- Mechanical bin agitator with separate 3/4 hp gearmotor drive prevents material bridging
- Sheave and timing belt drive components

Loss In Weight Features

Same as Volumetric above **plus:**

- Platform scale with floor support frame
- Loss In Weight Control panel which can be mounted on the floor support frame or independent of the feeder

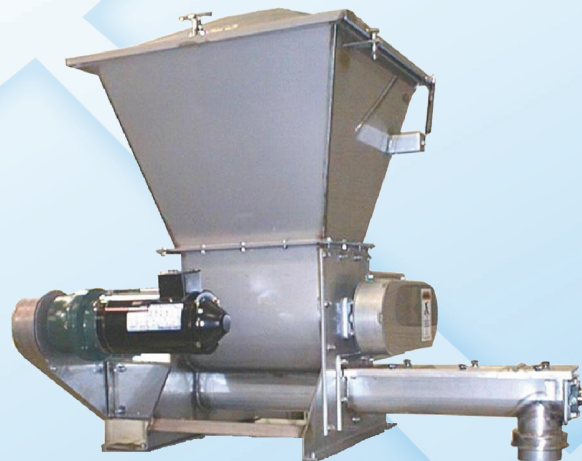

POWDER FEEDERS SPECIFICATIONS

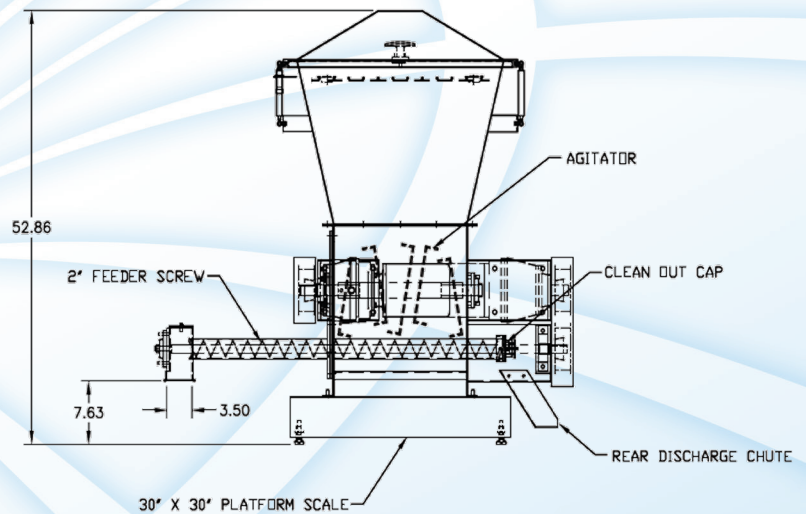
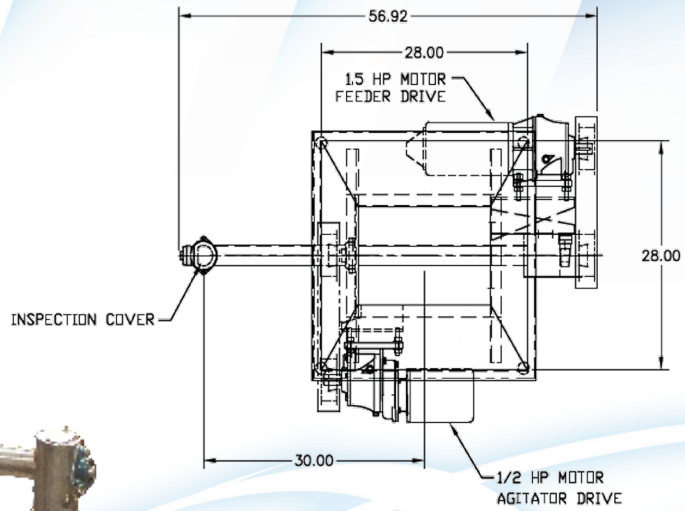

SINGLE SOURCE PROCESSING SOLUTIONS FOR:
Dry and Liquid Coating | Mixing | Weighing
Batching | Blending | Material Handling



APEC

Automated Process Equipment Corporation

1201 North Fourth Avenue
Lake Odessa, MI 48849 USA
Ph: +1 (616) 374-1000
Fax: +1 (616) 374-1010
www.apecusa.com



APECPOWFEED6/2019