

Hayssen DoyZip 380

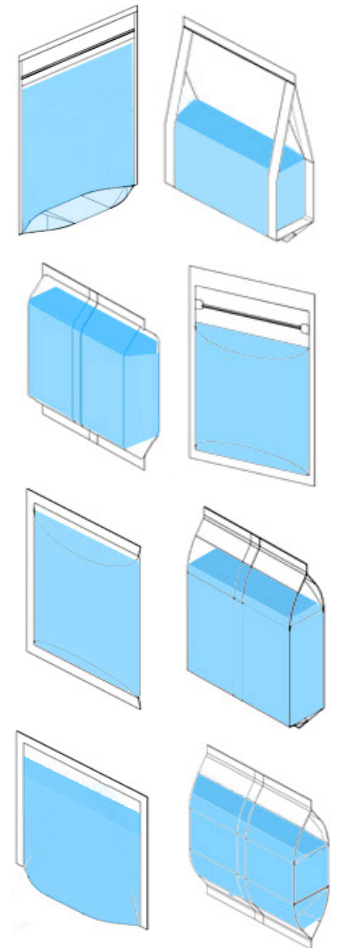

Features

- High speed intermittent motion VFFS bagger with precise film control to efficiently produce a wide range of bag formats, sizes, and shapes, all with or without zip reclose
- Versatility to make the complete range of bag formats Pillow, Gusseted, Block Bottom, Quad 4-Corner Seal, Doy and 3-Side Seal bags
- Sealing systems for polyethylene and laminate multi-layer films
- Biggest Doy bag available with a height of 380 mm
- Intuitive, icon driven operator interface with 10" Color Touch Screen Panel PC and remote monitoring/control capability
- Optimized productivity with quick change over times
- Servo motor driven sealing jaw actuation for high speed output and optimum seal integrity

Hayssen DoyZip 380

High Performance

Combining proven state of the art technology, customer driven features, and reliable design, the Hayssen DoyZip 380 VFFS intermittent motion bagger can efficiently produce a range of bag formats, sizes, and shapes, with or without zip reclose.

Have it all with the Hayssen DoyZip 380, one of the most versatile, efficient, and competitive machines on the market.

Standard Features

- ZIP ready for Vertical In-Line ZIP
- Intuitive Color Touch Screen Panel PC operator interface
- Servo driven seal jaw actuation for high speed, high force sealing
- 90° swivel seal jaw carriage to transition between Doy/Three-Side Seal bags and other bag formats
- Stepper motor driven friction pull belts with encoder feedback control for precise film advance
- Self-centering film transport pull belts
- Automatic film tracking and alignment
- Film registration photocell
- Electrostatic discharge idler rolls
- Near and end of roll alarm with film splicing station for quick roll changeover
- Tool free forming tube fasteners for quick changeover
- Storage for 100 product recipes
- Film oscillation product settling
- "V" device product catcher above sealing jaws
- Clear impact resistant 12mm thick methyl acrylate guards and doors
- Constructed with painted steel, stainless steel, and aluminum
- European CE compliance

Production Rate & Power Requirements

Up to 100 bags per minute depending on bag format and size

208–480 Vac, 50–60 HZ, 3 Phase+Ground, 8.5 KVA max

Options

- Vertical In-line ZIP system for Doy and 3-Side Seal bags
- Transverse ZIP system for all other bag formats
- Euro hole or Carry handle
- Easy open notch
- Allen-Bradley control system
- Full stainless steel and aluminum construction
- Vacuum pull belts
- Nip drive roll for film advance assist
- Quad 4-Corner sealing system
- Gusset device for Pillow or Block Bottom bag
- Flat bottom film fin bending/cooling
- Static elimination
- Gas flush and detection
- Dust extraction
- Remote monitoring/control and tele assistance/diagnostics package with IP webcam
- Integration with a variety of printers and labelers
- Product anti-bridging devices
- Strip bags with perforation for easy tear separation
- Film punch for Doy bag bottom gusset seal for mono-sealant films

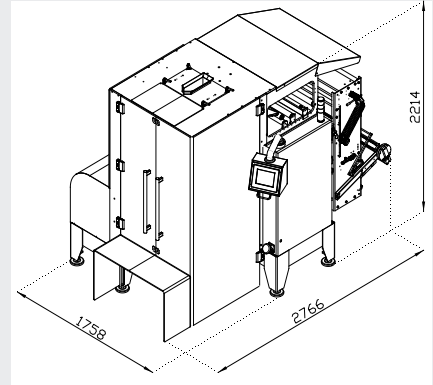

Footprint



Vertical sealing and forming tube details

BW Flexible Systems
225 Spartangreen Blvd.
Duncan | SC | 29334
UNITED STATES
t. +1 (864) 486 4000
bwflexiblesystems.com

BW Flexible Systems UK Ltd.
101 Lilac Grove | Nottingham | NG9 1PF
UNITED KINGDOM
t. +44 (0) 115 967 8787
bwflexiblesystems.com

Hayssen Flexible Systems S.r.l.
Via Trieste, 53 | Mestrino (PD) | 35035
ITALY
t. +39 049 9006511
hayssen.com

Schib Packaging S.r.l.
Viale del Lavoro, 7/9 A
Monte di Malo (VI) | 36030
ITALY
t. +39 0445 602300
schib.it

Hayssen | Rose Forgrove | Sandiacre | Schib | Simionato | Symach | Thiele