



DEVILLE
TECHNOLOGIES
INDUSTRIAL FOOD CUTTING SOLUTIONS

***High Capacity Solutions for
Pet Food Manufacturers***



Paul Krechel
Market Manager-Protein Industries

About Us

- 35 years experience in the industrial food equipment industry 1982

- Specialize in industrial food cutting solutions - 1998

- Design, manufacture and distribute FAM equipment (exclusive North America Distributor)

About Us



- Client Center – Canada and USA

- Provide complete line solution from product handling up to packaging

- Custom Solutions

Deville Technologies

- Partner with our clients to build long term relationships
- Develop complete solutions that deliver *business value*
- Design, test, and build equipment to deliver a perfect cut quality with impeccable hygiene

Client Support

- Deville Canada
- Deville USA
- Client Centers



Service

- Gold Standard
- 24/7 support
- Dedicated Project Team



Holistic Approach to Sanitary Design

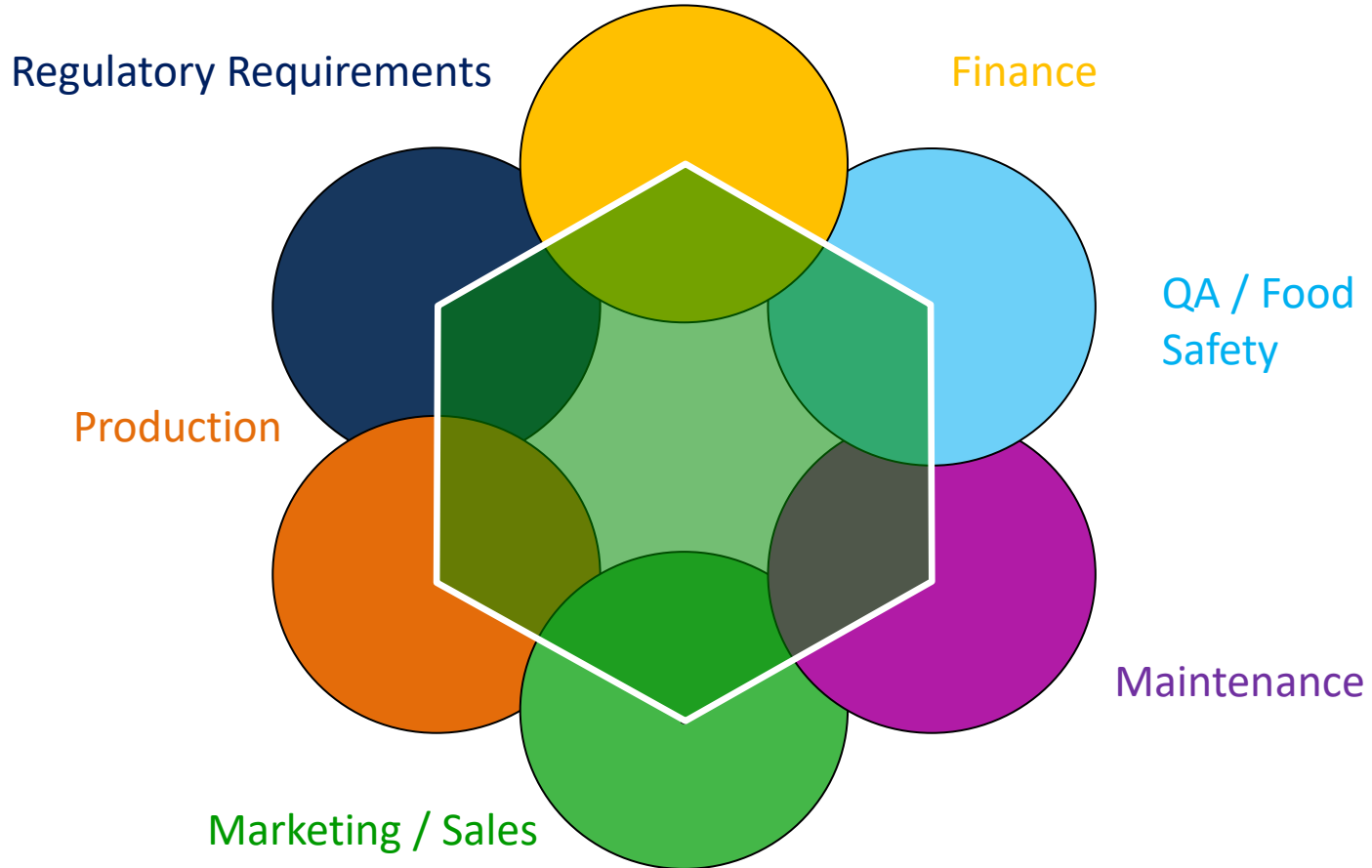

Slice, Dice, and Shred Deville/FAM



Incline Conveyor



- Transports product to dicer
- $\frac{3}{4}$ HP Vandergraph drum motor, w/ Allen Bradley PowerFlex 525 VFD
- Tool-less disassembly
- Cantilever design for easy belt removal

1 Dimensional Cutting



- Mantis.2
 - V-Belt Slicer
 - Key Applications
 - Coin Slicing
 - Sliced chicken breasts
 - Pepperoni/sausage logs
 - Protein Strands
 - Vegetables

Mantis.2

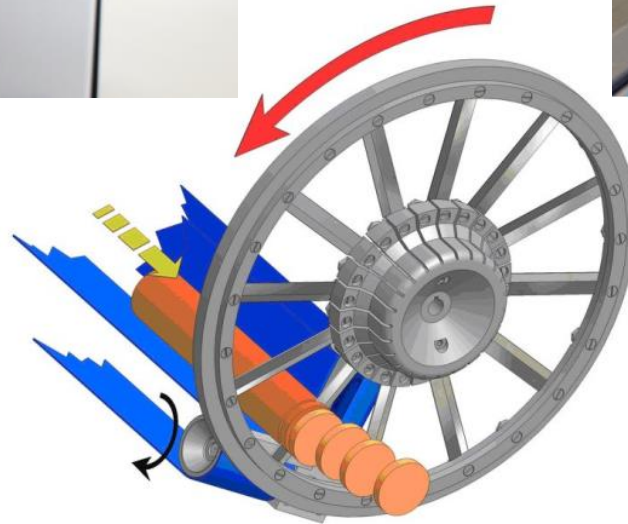
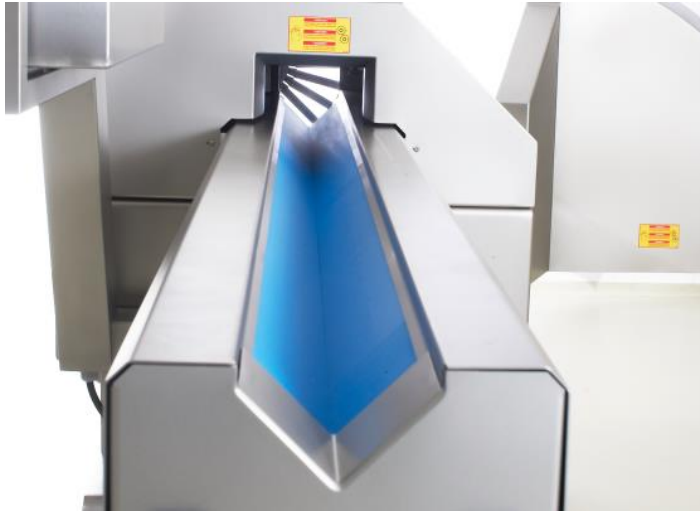

1 & 2 Dimensional Cutting

- GD500
 - Guillotine Style Slicing and
 - Straight or Crossed Blades



GD500

Cutting principle



DEVILLE
TECHNOLOGIES

3 – Dimensional Dicers CMD.2 and Flexifam



Dicer Selection Principle

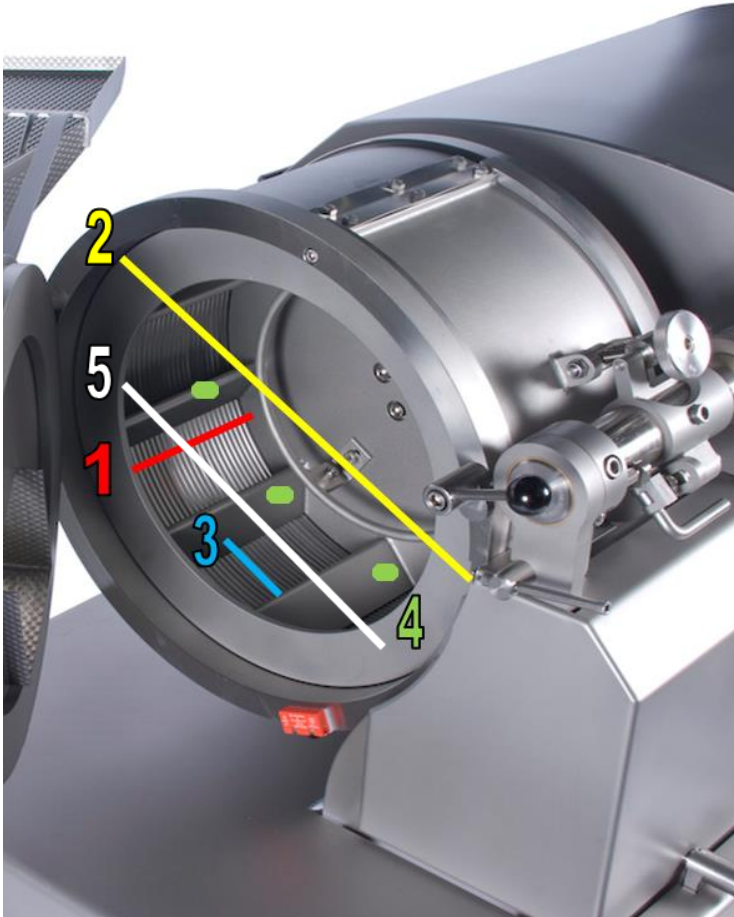

- Selection
- Size of the drum
 1. Drum depth
 2. Inner drum diameter
 3. Distance between 2 adjacent paddles
 4. Number of paddles
 5. Paddle wheel opening
- Cut sizes
- Capacity

3 Dimensional Cutting

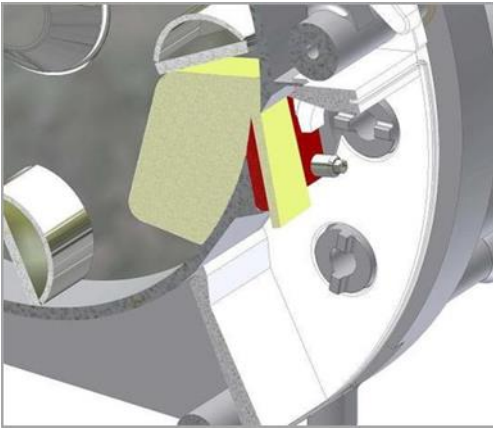

Slice

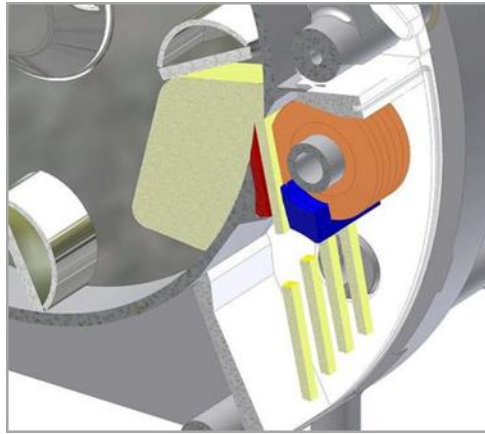

Strips

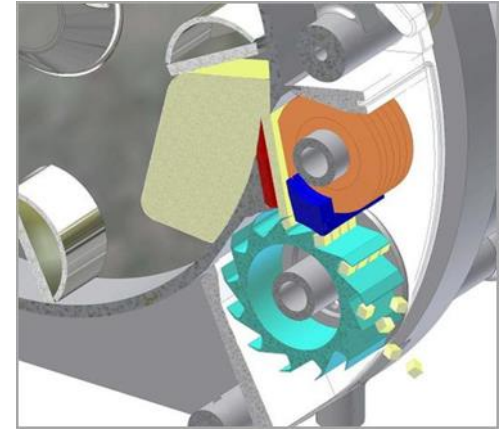

Dice

Flexifam

Medium Capacity Dicer



- 2,000-9,000 lbs/hr. *depending on cut size*
- Variable Frequency Drive
- Complete separation between drive and product zone
- Acceptable Cube Size: 5 inches
- Cut Sizes : 1/8" – 5/8"

Flexifam Cutting Principle

1. Circular Assembly
2. Shear Plate
3. Crosscut Assembly
4. Product
5. Slice Knife
6. Impeller Wheel
7. Drum

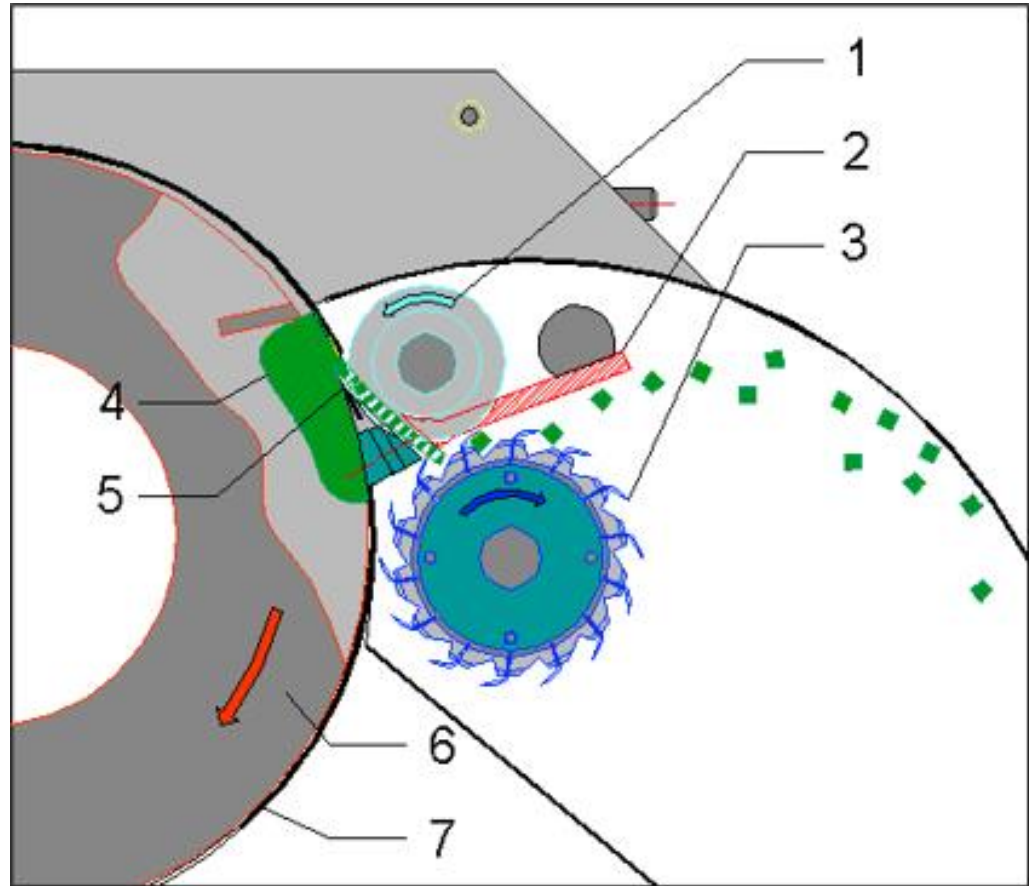
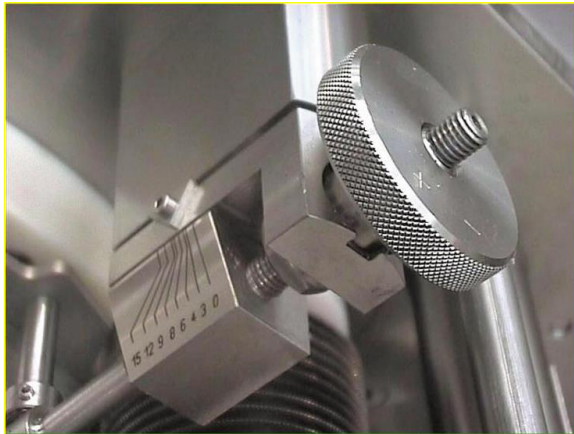

Flexifam Cutting Zone



- Slice Knife
- Knife Holder
- Circular Knife Assembly
- Shear Plate
- Crosscut Knife Assembly

CMD.2 – Frozen Products



- Dices (1/8" - 1")
 - Fresh Chilled
 - Fresh Frozen
 - Cooked
 - Cooked Frozen (Food Safety)
- Large Drum Size for high capacities
- Heavy duty reinforced blades
- Robust design

CMD.2 Cutting Zone

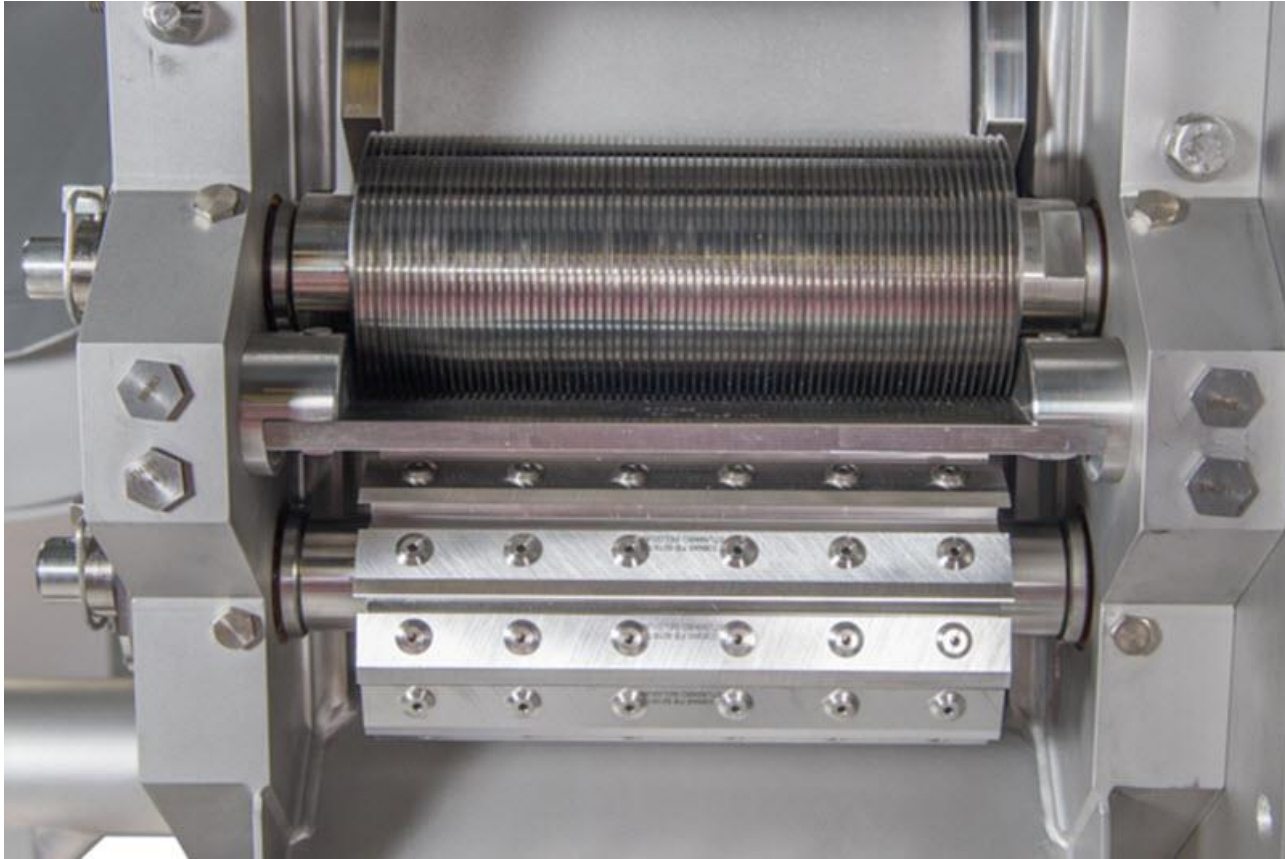

Complete Separation between product and mechanical zones

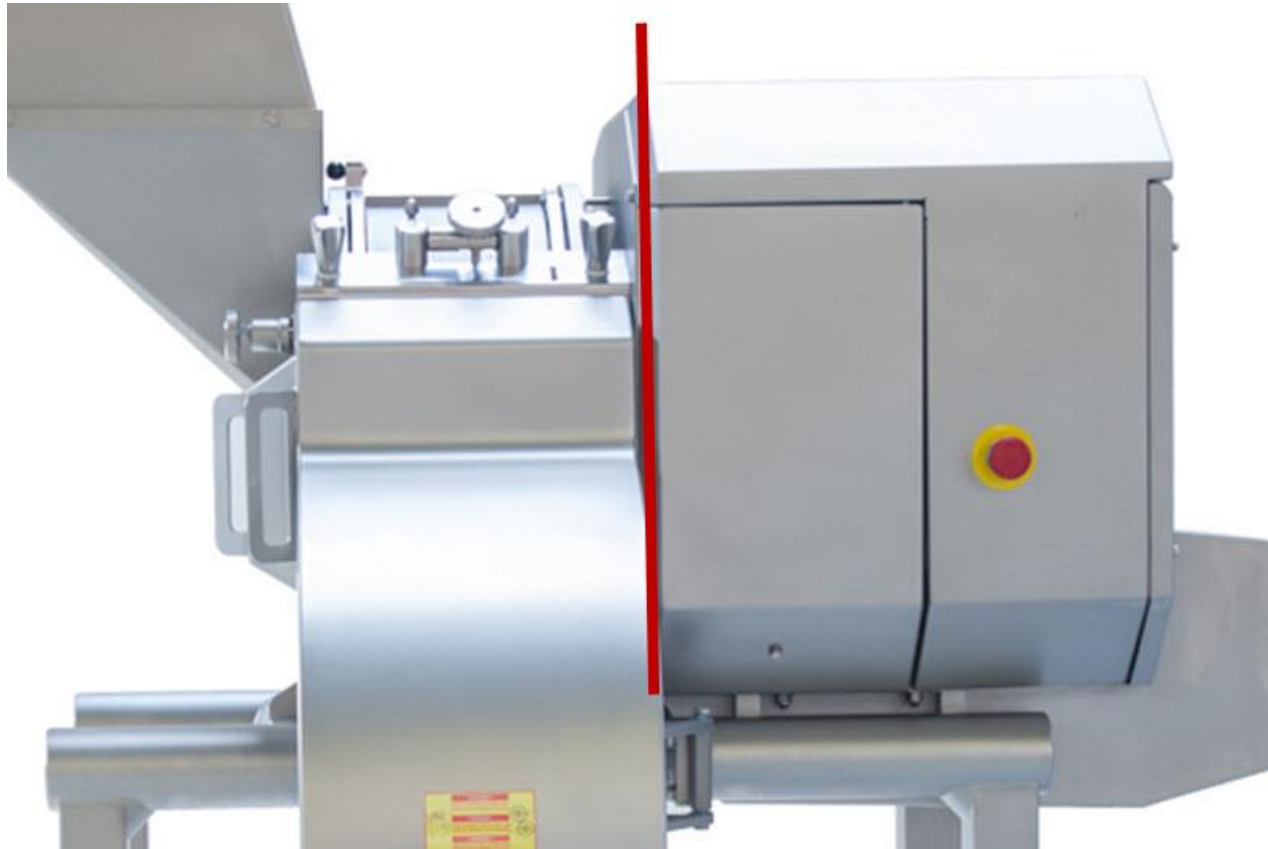

Hymaks – USDA



- USDA Dairy Equipment Accepted
- High capacities up to 12,000 lbs/hr
- Automatic calibration of slice thickness
- Dice Sizes 1/8" - 1"

2 – Dimensional Cutting

Yuran Hytec

- 2- Dimensional cutting
- Dice and strip cutting
- Pulled look applications
- Separation between drive zone and product zone
- Medium capacity and high capacity options
- Hygienic design



Adjustable Shred Configurations

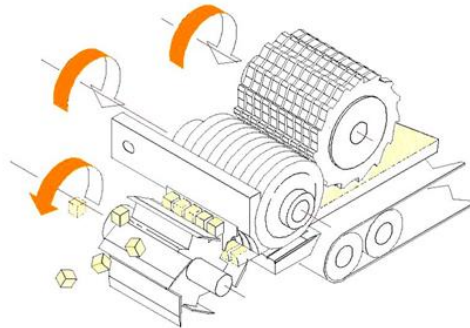
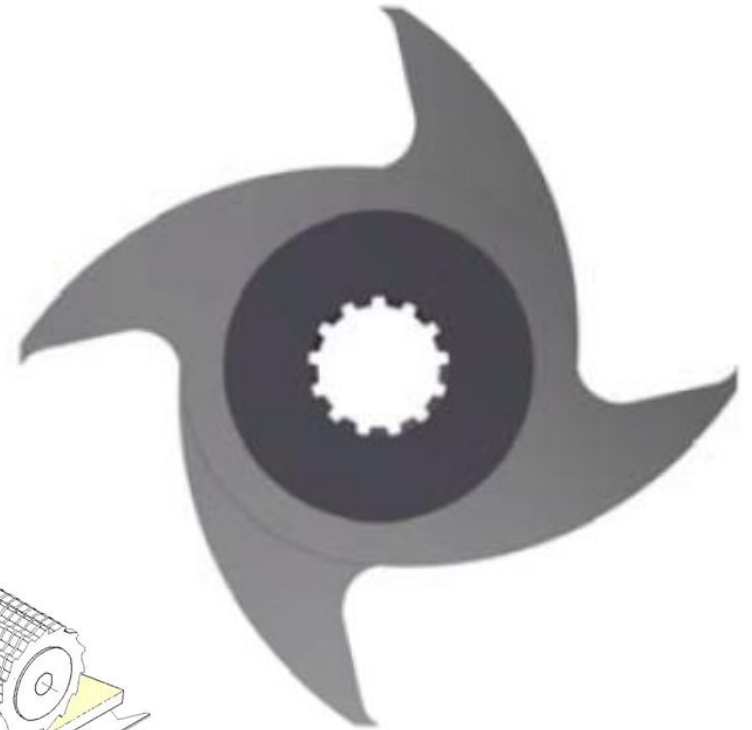
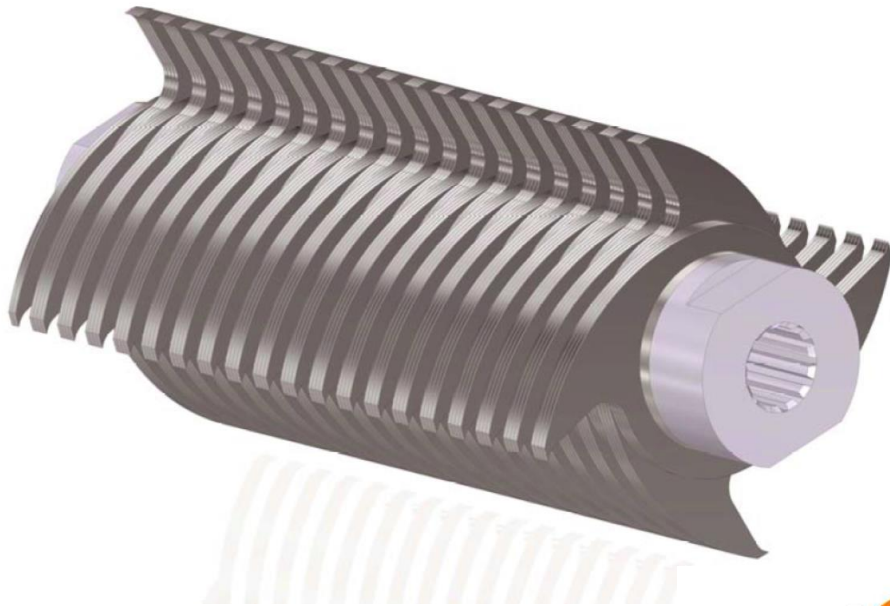

Configurations

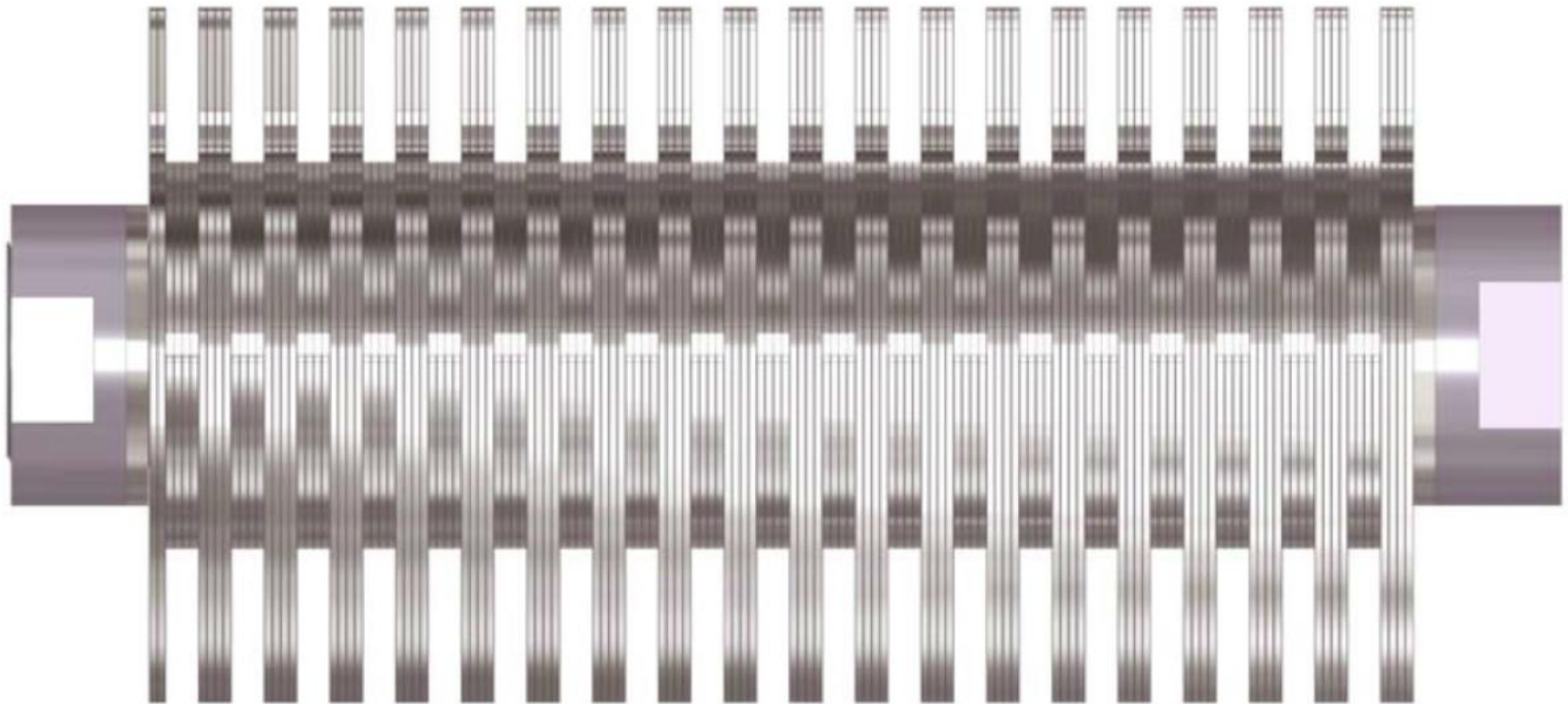

Yuran Hytec Features

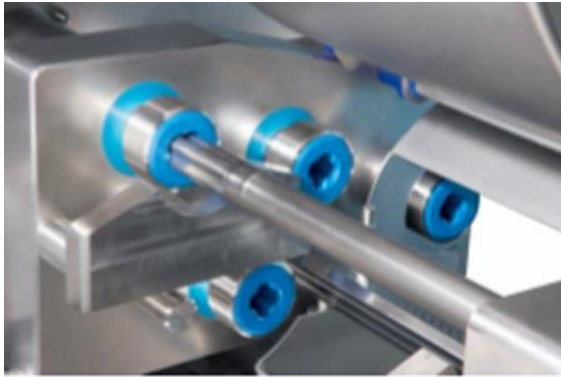

Cutting tools with hygienic positioning shafts with clover profile.

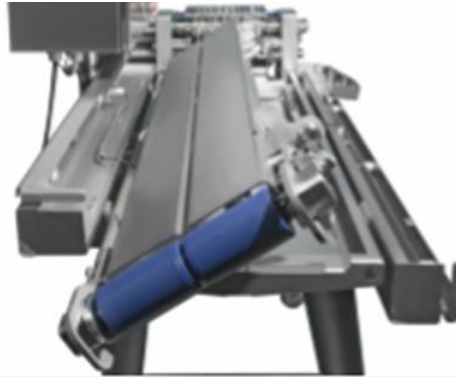

Quick and ergonomic system for removal and tensioning of feedbelt.

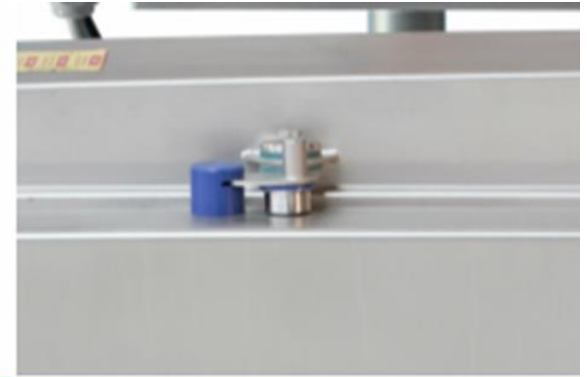

Only 2 stainless steel safety switches prevent the machine from operating with open cover.



DEVILLE
TECHNOLOGIES

Yuran Hytec Features



The machine is completely manufactured in stainless steel. No bronze bushings or corrosion possible.



Equipped with three-phase stainless steel motor for low energy consumption and designed for easy washdown.



The drive zone and the product zone of the machine are completely separated.



DEVILLE
TECHNOLOGIES

Ancillary Equipment



Deville Exit Conveyor from Dicer



Exit Conveyor from Dicer

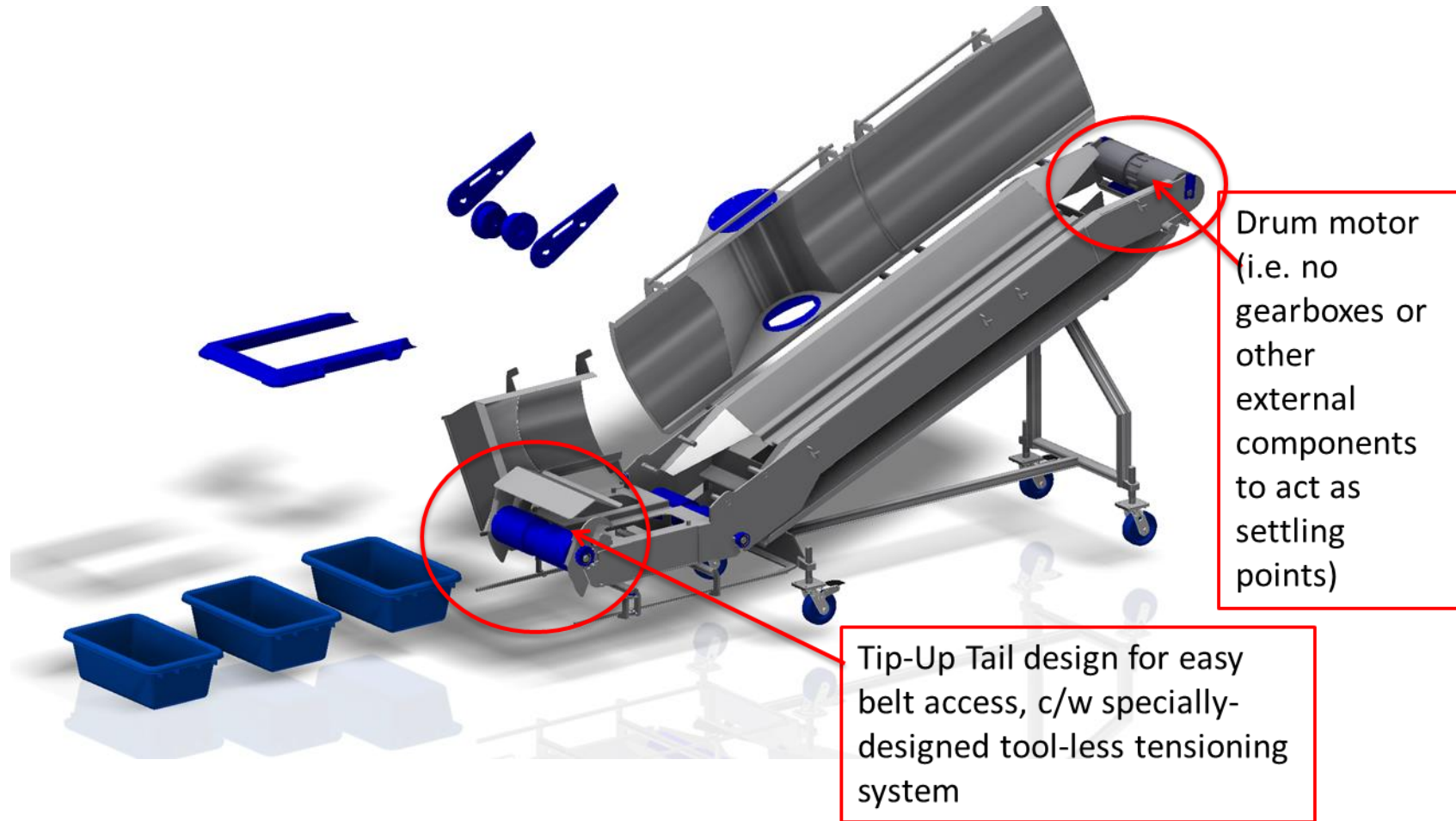

Deville Exit Conveyor

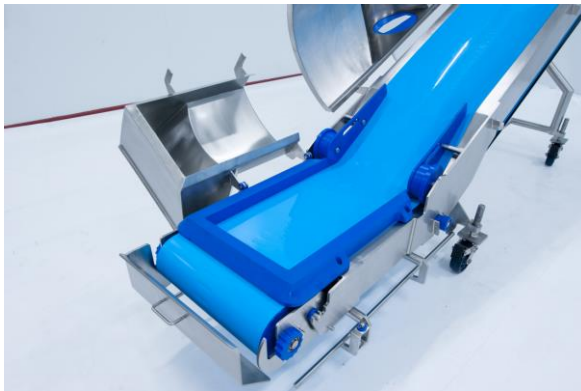
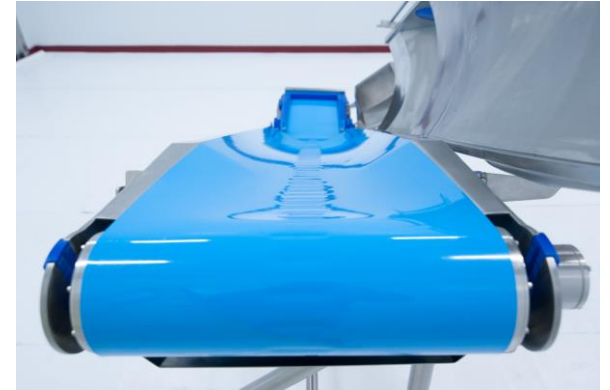

Deville Custom Conveyor to Scale

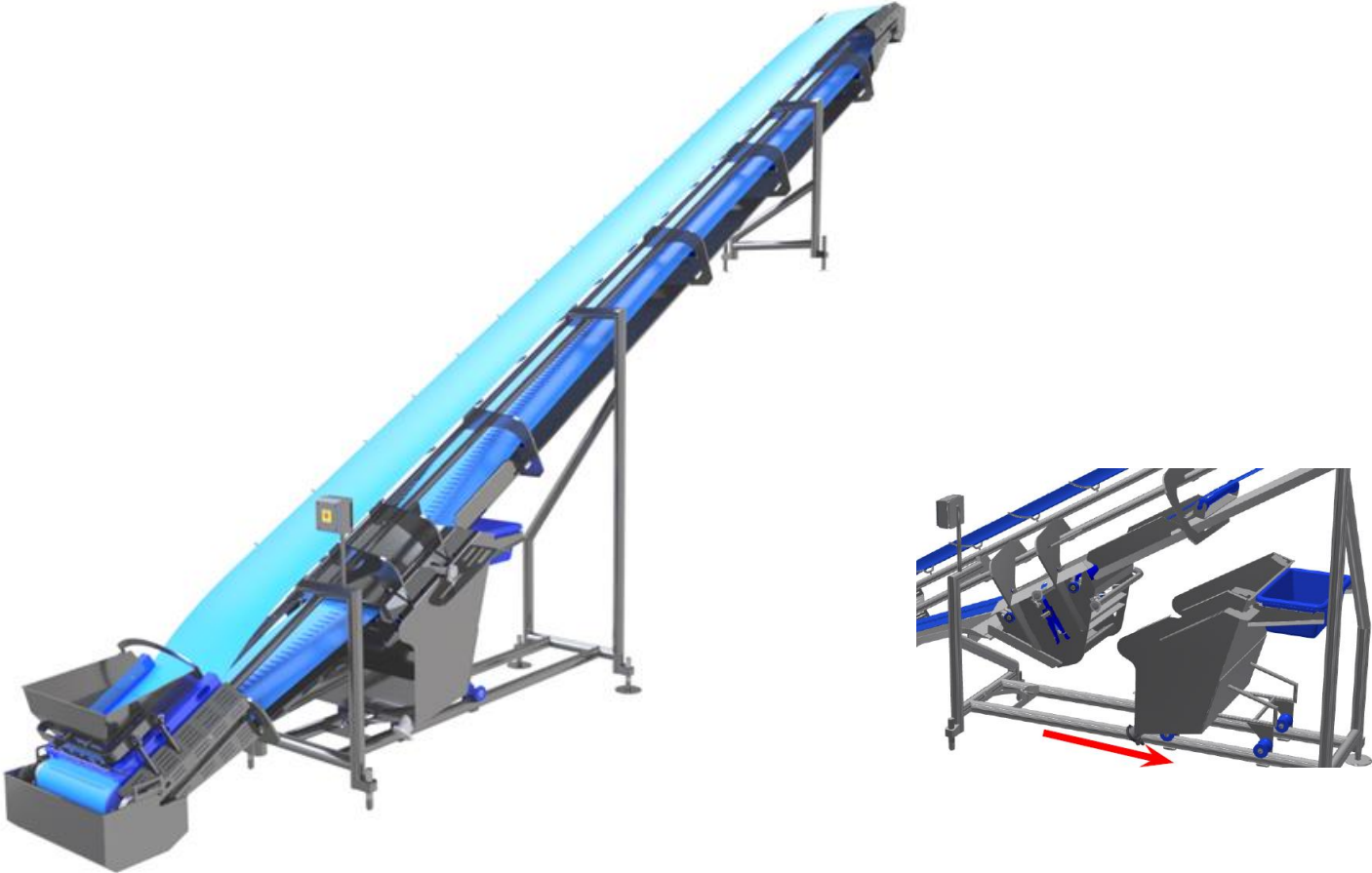

Deville Conveyor to Scale

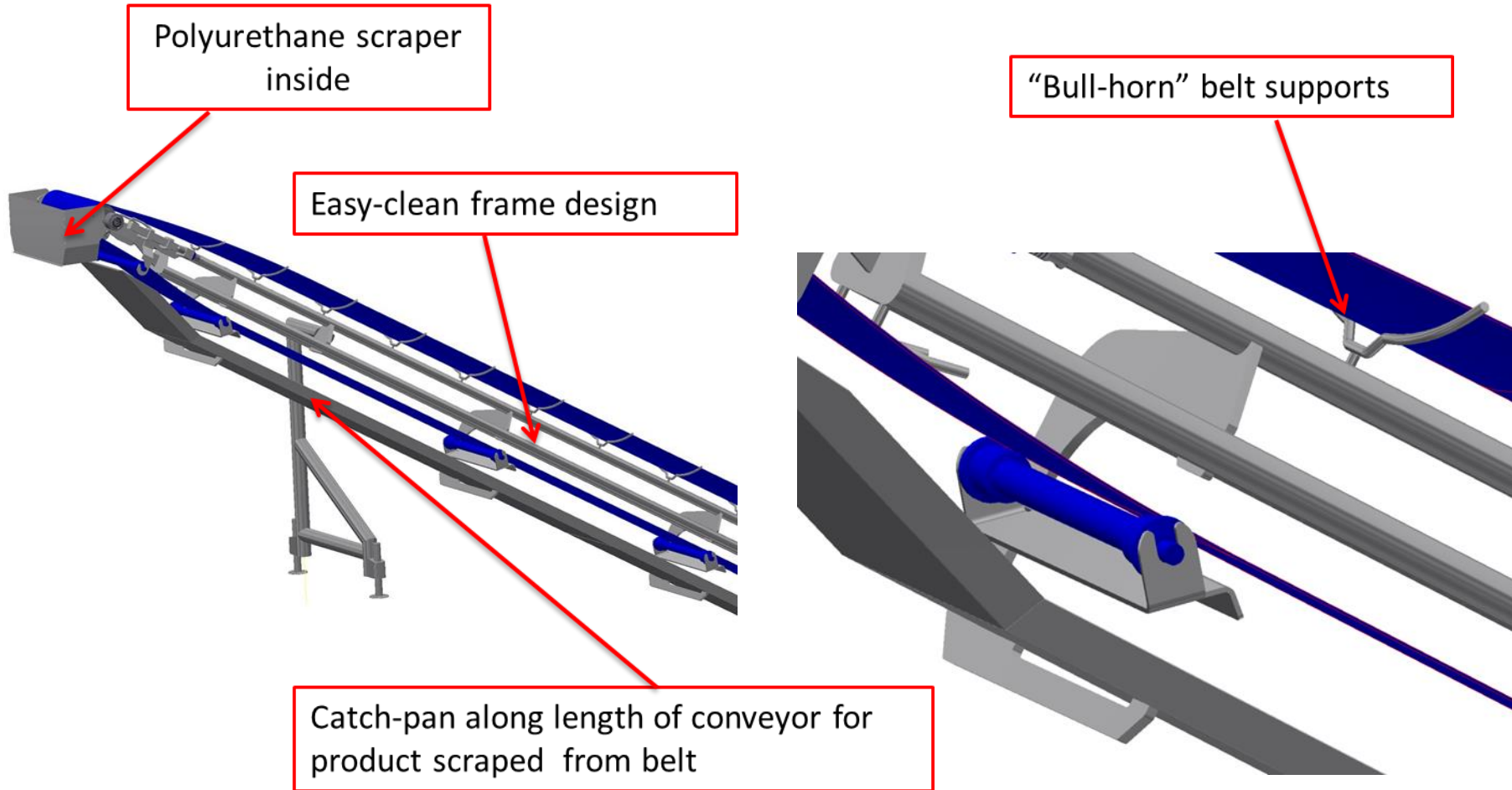

Conveyor CIP Option

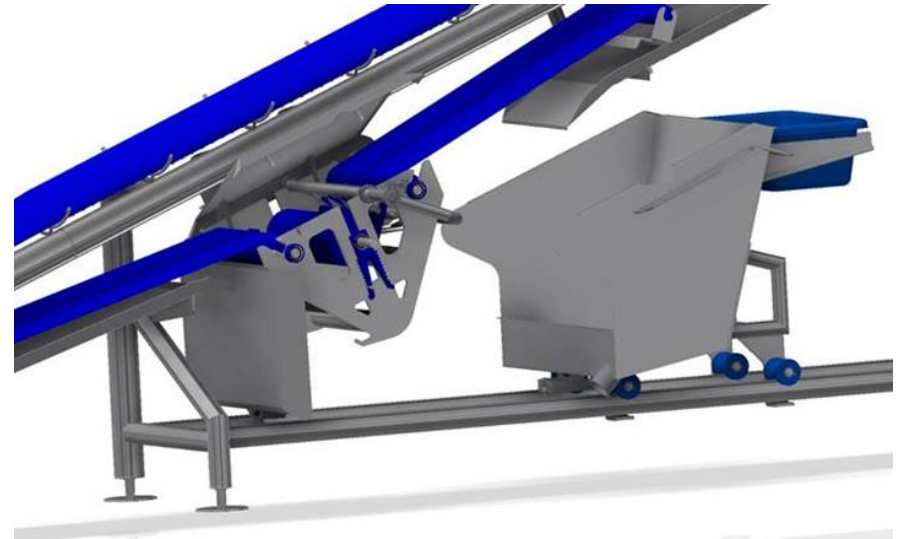

- CIP system for on-line continuous pre-cleaning of belt with hot water or caustic solution
 - Tank designed with inlet and outlet ports, and can be designed to allow cleaning-solution recirculation
- Easy-open access on integral rails

Conveyor CIP

- Integral high-pressure nozzles to clean top and bottom of belt

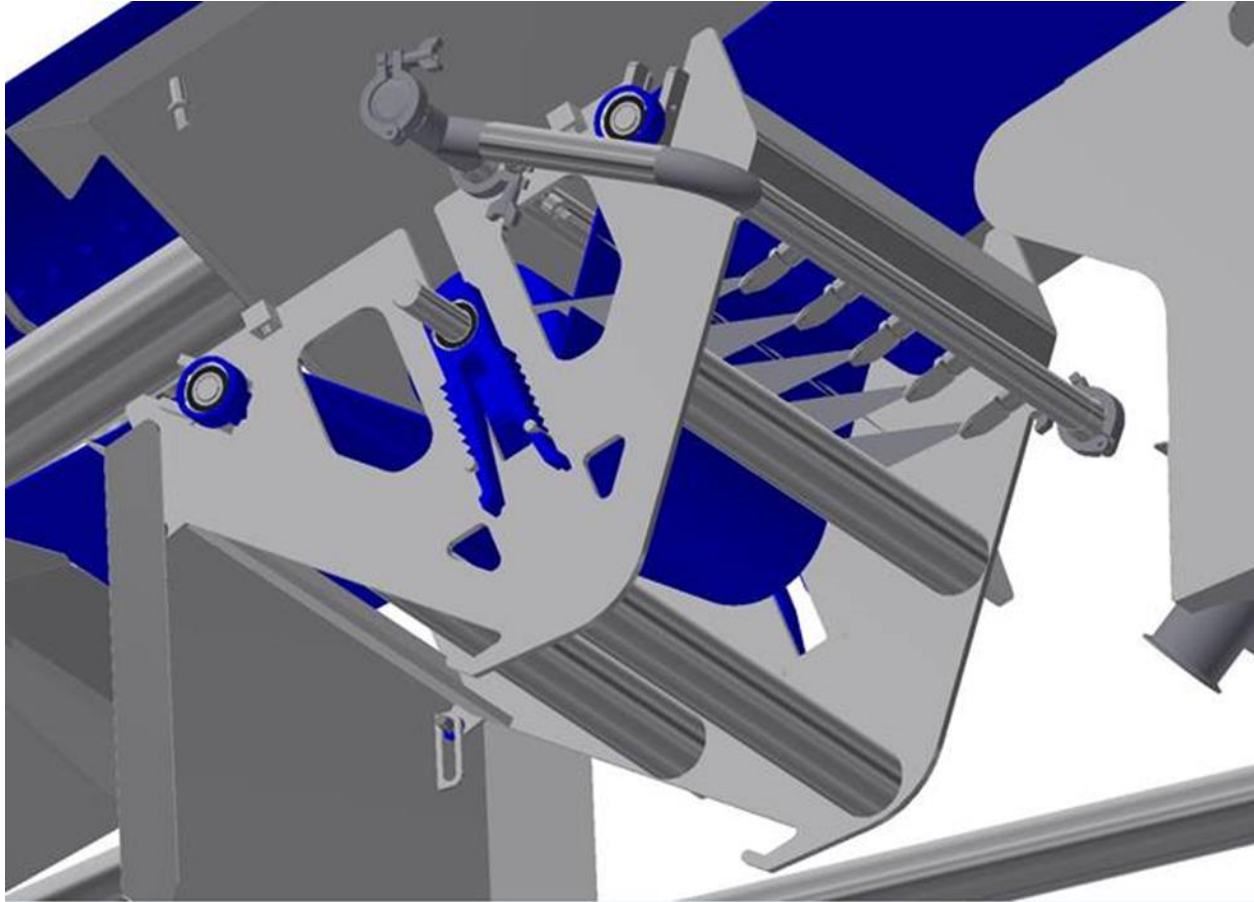

DEVILLE
TECHNOLOGIES

Cutting Tool Trolley

Storage and Sanitation

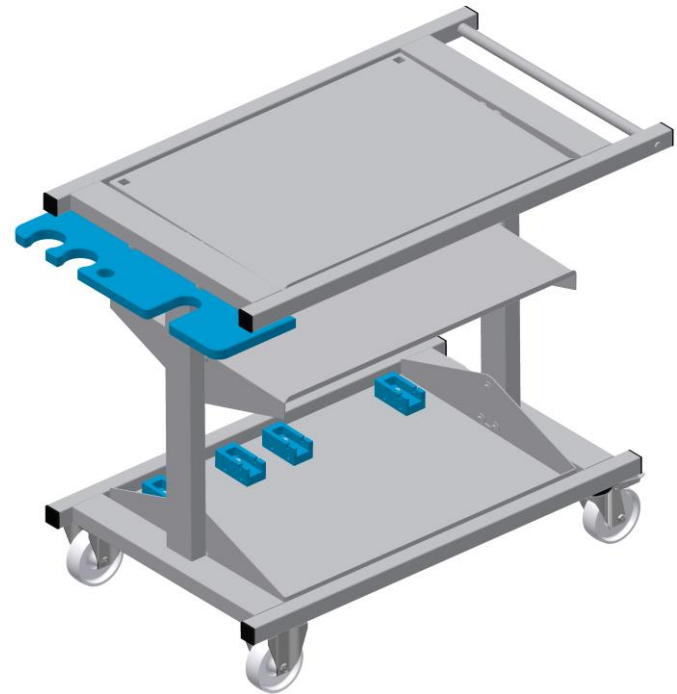

Full Line Wash Cart



Dice Line Wash Wall Option

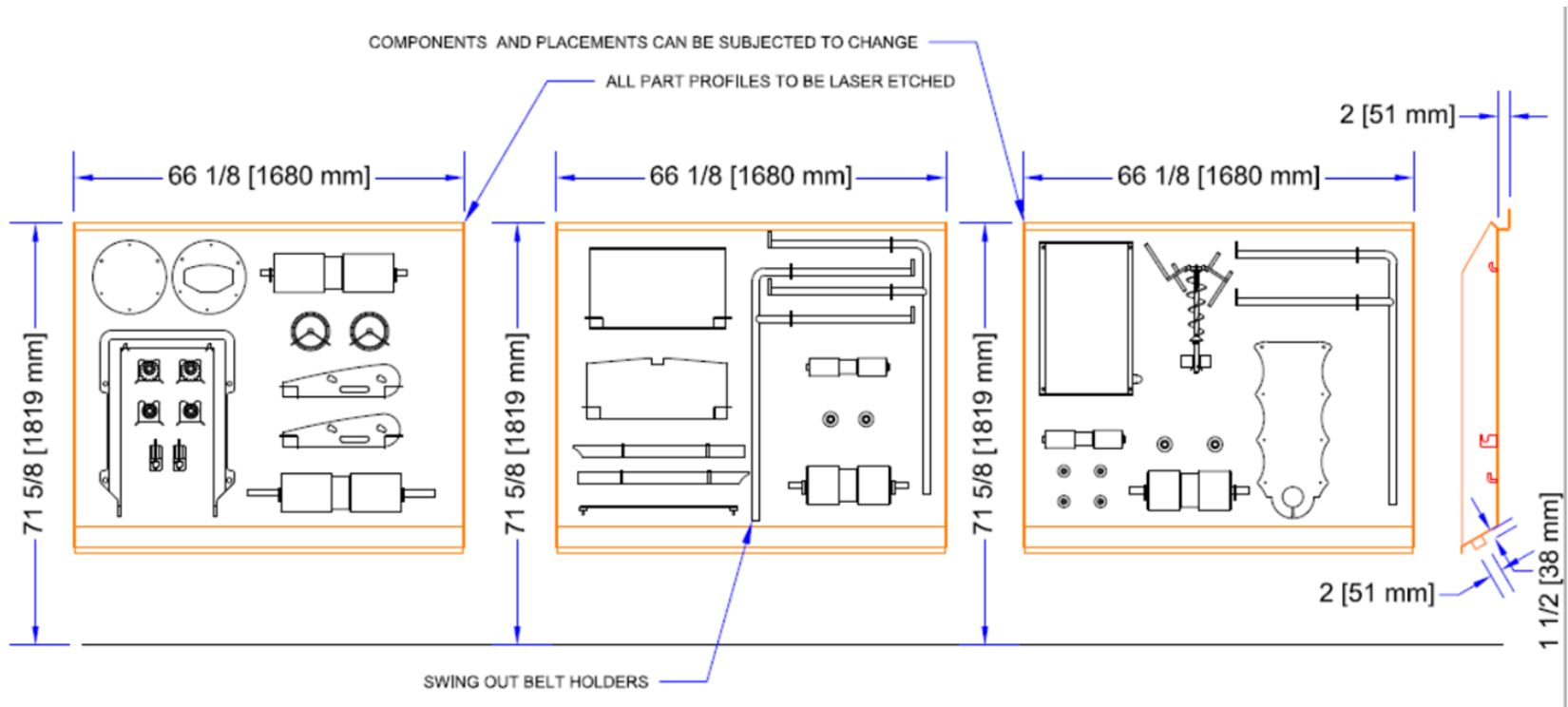

Flexifam Dice Line

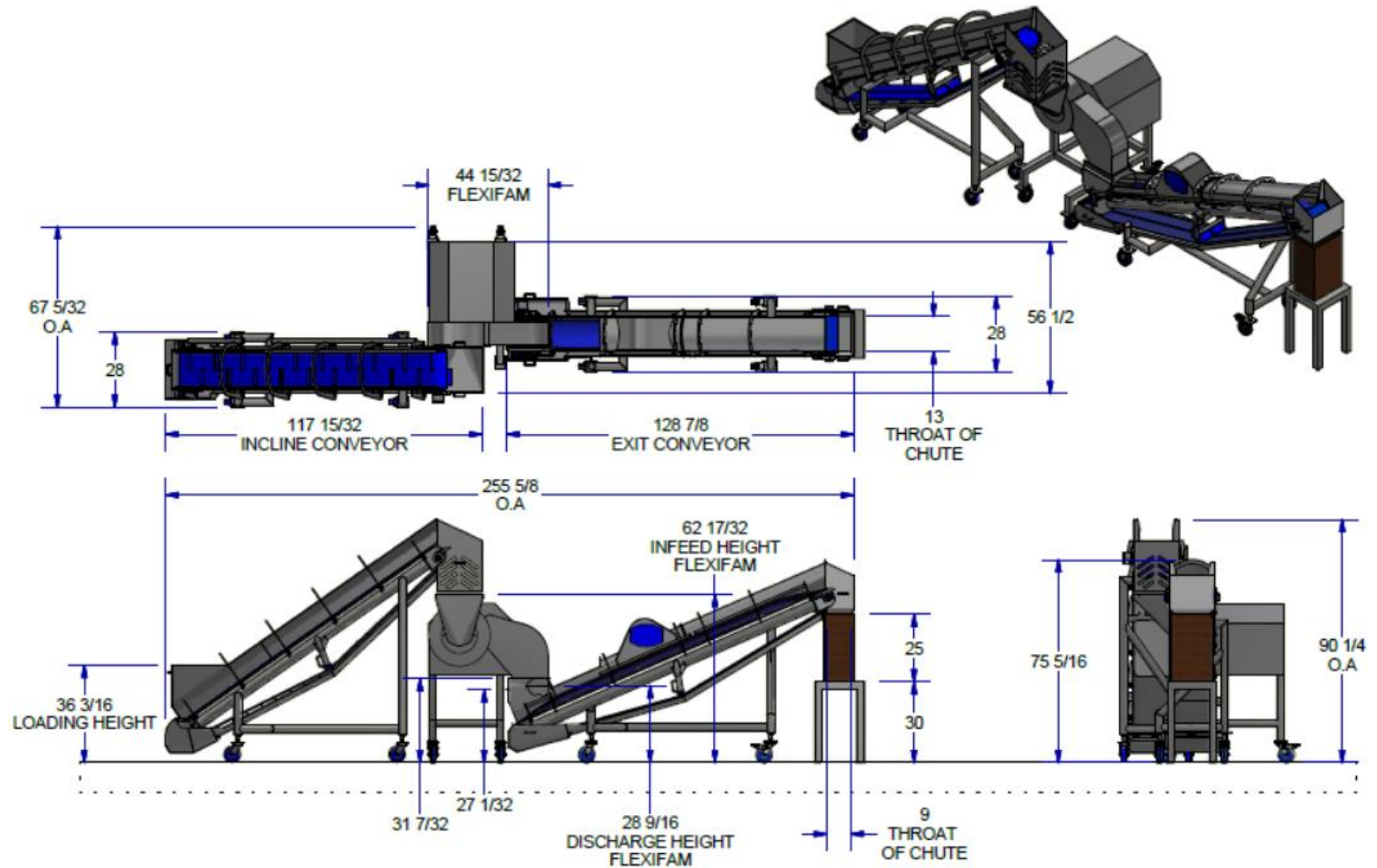

Flexifam Dice Line

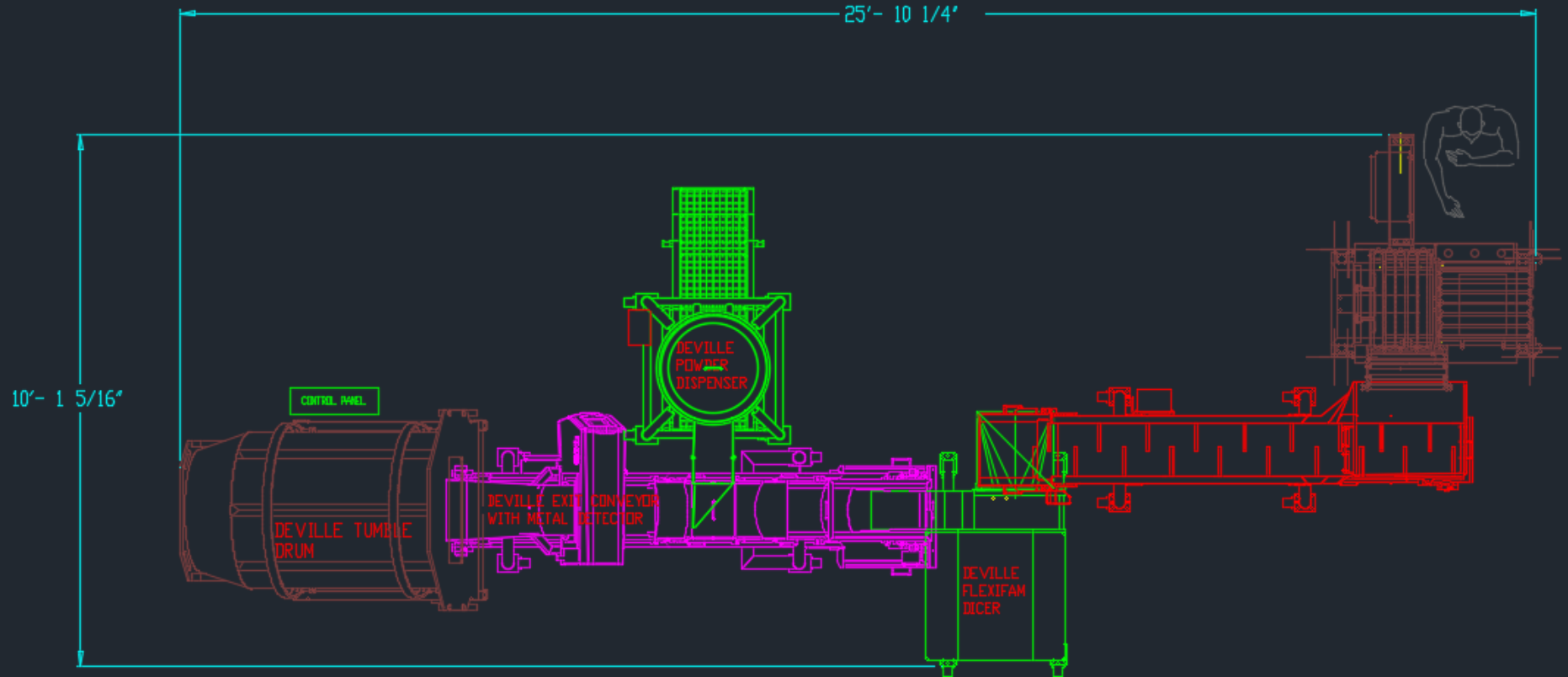

DEVILLE
TECHNOLOGIES

Hymaks Dice Line

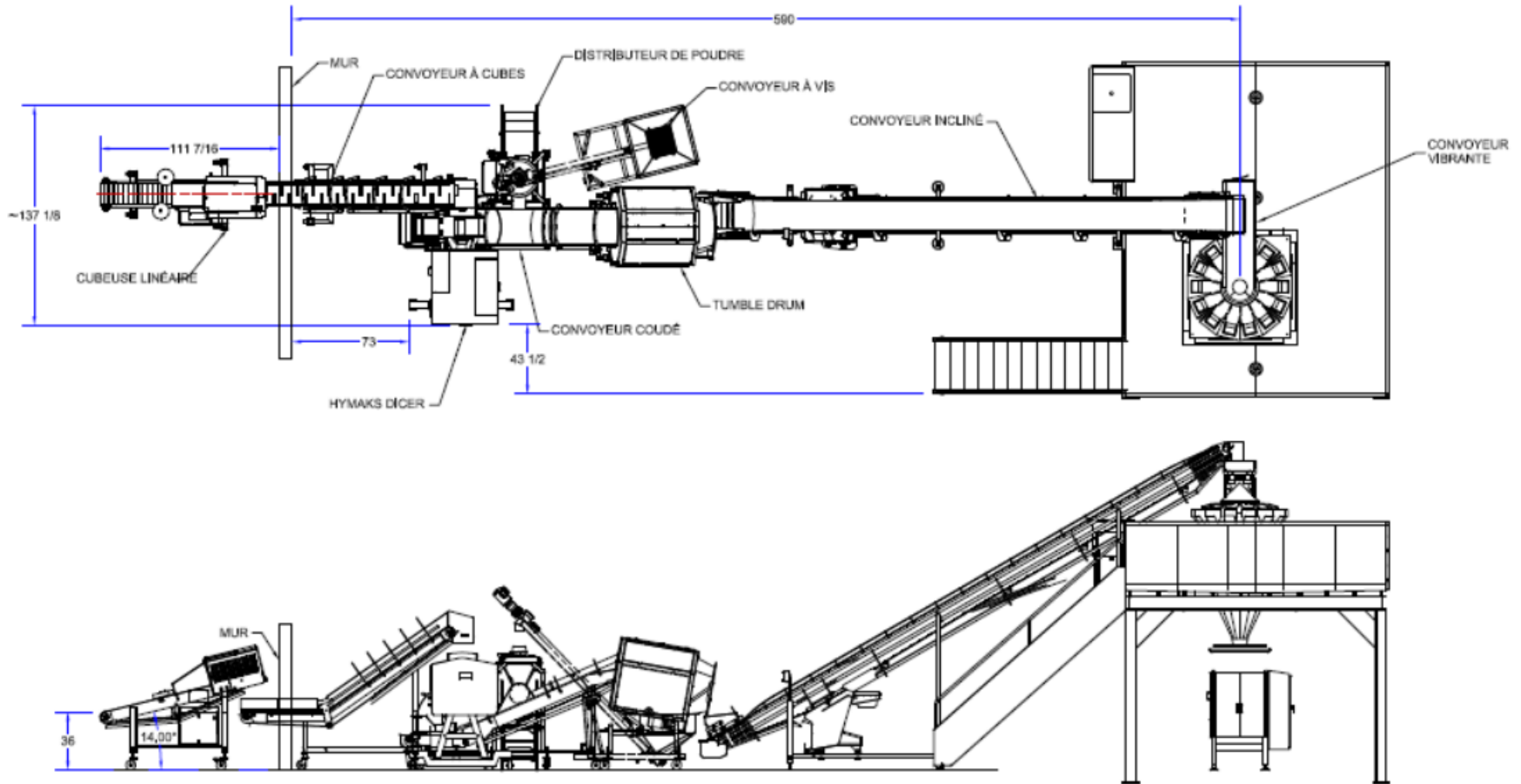

Questions?

