

PETFOOD OUTLOADING CONCEPTS

FINISHED KIBBLE HANDLING FROM SILO TO PACKAGING



OPTIMIZE FINISHED PRODUCT

ELIMINATE CROSS-CONTAMINATION & DAMAGE OF

- High capacity finished kibble dosing and blending with 100% flexibility from silo to packaging
- Perfect homogenous mixture by using a weighing mixer with minimal kibble damage
- No cross-contamination due to effective slide vibration and clean swipe
- Compact design minimizes solution footprint and building height.

Multiple loading and discharge positions

The ALFRA BUV is a moving finished product weighing system for quick and clean loading of materials. It is able to collect large volumes of finished product in exact quantities, like: kibbles, flakes, granulates and other fragile products. The BUV system has the possibility to discharge at multiple locations. These locations can be a counter bin but also a packaging line or a mixer. As such, there is minimal risk of

cross-contamination, because our systems work without conveyor belts, pneumatic tubes, chain conveyers or other types of conventional transport. Our BUV systems are easy to clean, require less building height and can be installed in brown- or greenfield situations.

Thanks to our special designed pet food dosing slide, kibbles aren't damaged during the dosing process.

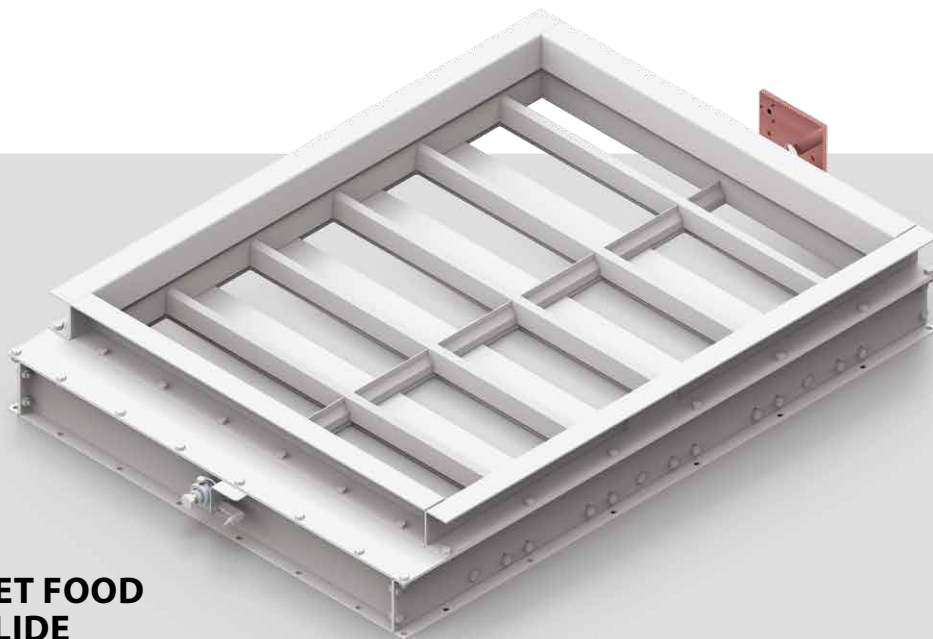

UNIQUE PET FOOD DOSING SLIDE

ALFRA developed a special dosing slide for finished kibbles. We equipped the dosing slide with a smart operating system that is self-learning, this means that the software takes the flow characteristics and handling requirements of these fragile kibbles into account and will use this information to continually optimize the operation of the dosing slide. This functionality, in combination with the design of the slide, will prevent that kibbles are cut during the dosing process while maintaining a high capacity and accuracy.

Secondly, the slide is equipped with vibrators and a clean swipe to remove remaining product from the slide. This ensures a complete emptying of the bin and prevents cross-contamination in situations where the bins are used for a variety of products, minimizing the chance of contamination on colours, shape, odour or flavour.

HANDLING AND BLENDING

FINISHED KIBBLES



HANDLING AND BLENDING FINISHED KIBBLES

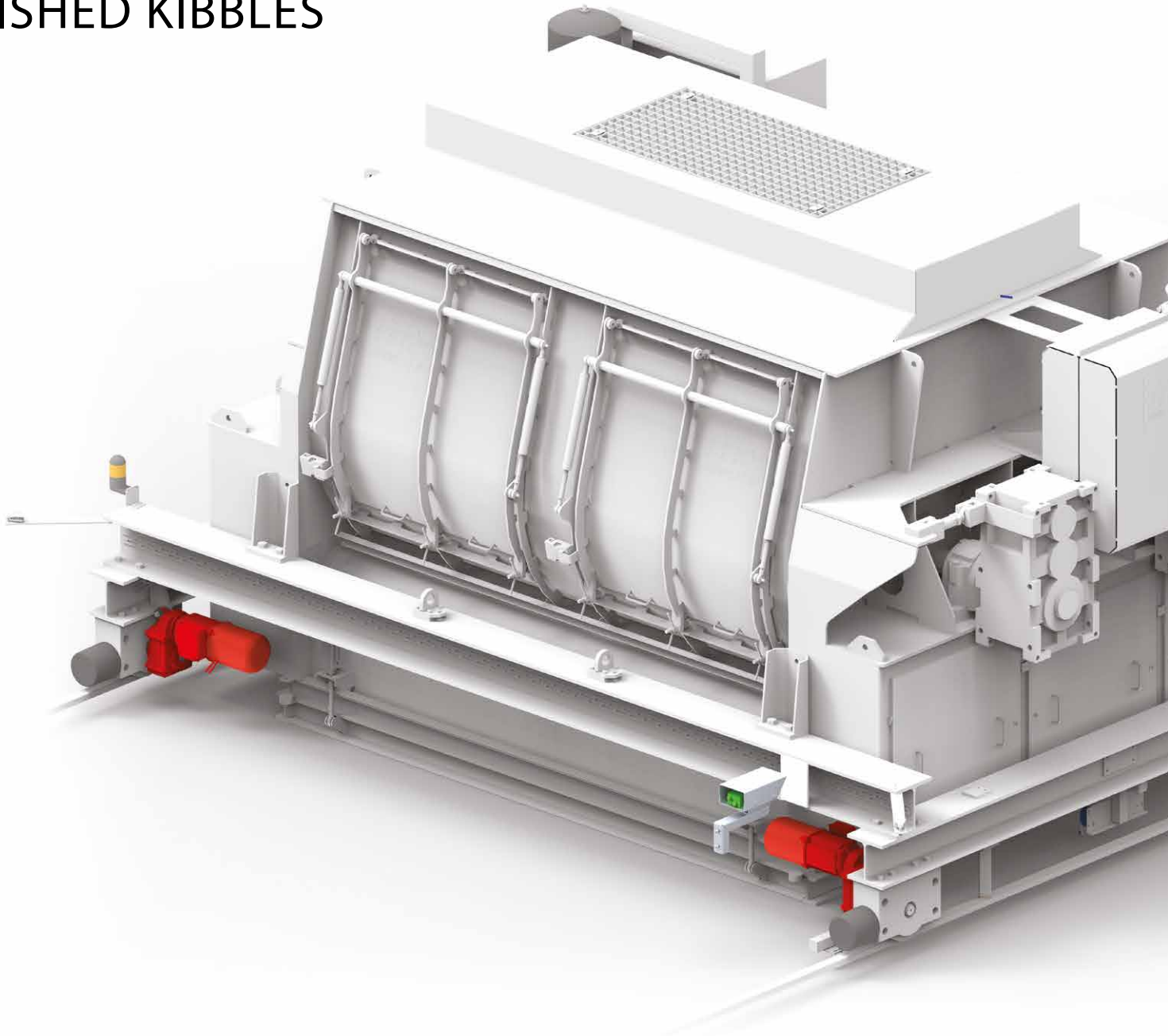

BUVM a self-driving weighing mixer

The BUVM is used for end of line mixing of finished kibbles and/or flakes. It can position itself to and from any designated location within its zone of operation. This unique freedom of movement allows the BUVM to collect, dose and weigh from any product silo and unload the mixed products at various discharge locations. The mobility of the BUVM eliminates the need for additional mechanical means of transportation, that are often expensive and risk de-mixing or even damaging the final product.

A possible feature of the BUVM is the weighing option. The mixer will then be installed on loadcells to guarantee the correct ratio is maintained between special additions, colours, or other products. Weighing is done

instantaneously during the dosing of the product from the bins, directly into the mixer. Therefore, the mixer can be used to collect directly from several finished good kibble and/or flake silos.

The flexibility of the BUVM to collect and mix products from any given silo eases the process of testing new products using a new recipe. It provides your production line with the flexibility you need to reduce the 'Time to Market' for new or client specific products, from initial idea to the first bags of commercial products. Moreover, the BUVM features optimal mixing characteristics of finished products, and prevents cross-contamination. All the ingredients you need to make your factory future-proof and reduce your time to-market!

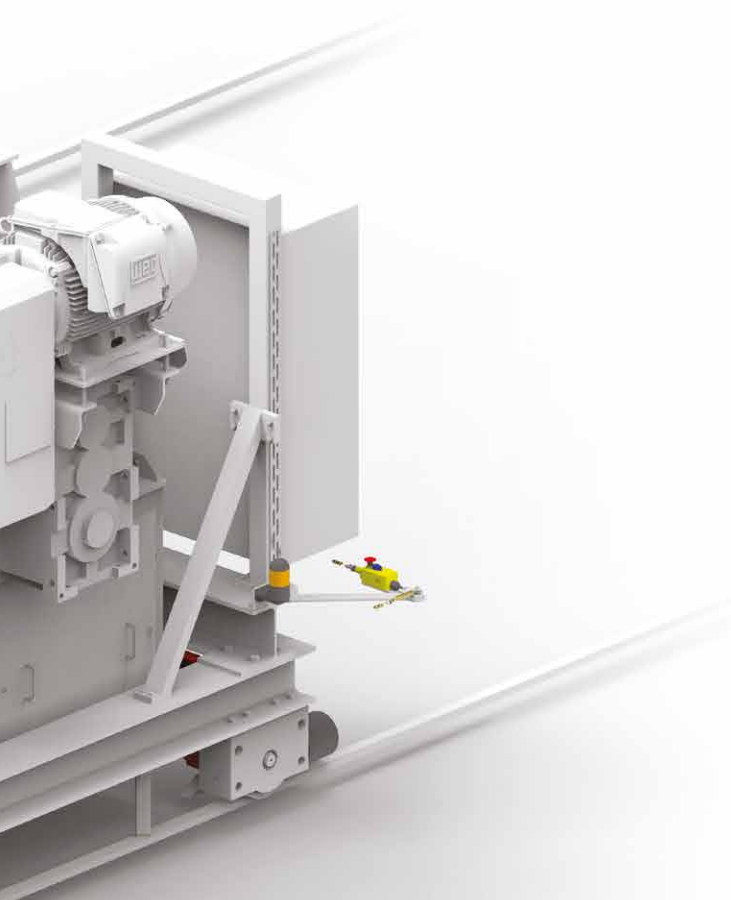

Containerized transport with ALFRA ACT

Prevent contamination in your factory with the ALFRA Automatic Container Transport (ACT). The ALFRA ACT replaces all conventional ways of transport with containerized solutions. Containers will be dedicated to specific ingredients or finished products to eliminate the risk of cross contamination. Even finished products can be divided into several groups such as organic, grain free, cat/dog or re-work. KSE is your partner in this factory of the future concept with multiple sites worldwide using this full concept!

Each container has its own RFID chip and is fully closed during transport and storage. This makes the containers suitable for temporary storage of (finished) product. This gives you the flexibility to decide what packaging method will be used at the exact moment when you need the product. Moreover, production batches can be divided over several containers, feeding multiple packaging lines. These containers can therefore keep multiple production lines going, without needing to clean or flush the conventional mechanical means of transportation between product groups.

Our finished product containers can be made of stainless steel or the patented KSE flexible container solution (another unique KSE solution to reduce bridging and ratholing and other typical container issues!). Containers can be cleaned fully automatic in our 'clean in place' line. This is a three-stage cleaning process which guarantees a clean container. The first stage consists of dry cleaning the container, stage two uses UV light for the disinfection of the container and the last stage features an automated visual inspection of the inside of the container indicating that the container has been cleaned and is ready for the next load. Thanks to the RFID chip in the container, all Track & Trace information will be logged into your system. This is the critical component that simplifies the reporting process, as it automatically keeps track of the product/container history and records when the container was last cleaned.

*Interested in solutions that help you build
a Factory of the Future?*

*Contact our experts to discuss your project
/ E-mail us at sales@kse.nl*



Dosing & Weighing Technology

Specifications BUVM

Container volumes	500 to 9000 liter
Container capacities	420 to 7500 kg
Execution	carbon or stainless steel

Specifications BUV

Dosing range	5 kg to 10000 kg
Weighing capacity	1000 kg to 10000 kg
Dosing accuracy	+/- 1 kg to 5 kg

Specifications ACT

Container volumes	1500 to 5000 liter
Container capacities	Up to 3000 kg

See also

ALFRA BUV
ALFRA ACT
ALFRA DS

KSE: what we do

KSE Process Technology is a family business that has grown steadily over the last 40 years to become a worldwide concern. We supply everything your factory needs to dose, weigh and transport your materials. Besides dosing and weighing systems themselves, we provide automation solutions and services for producers of powders, pellets and granulates for the animal feed and related industries.

The portfolio of KSE dosing and weighing solutions covers everything from micro up to macro components, with dose rates from 1 gram to above 6,000 kg. Next to this, KSE's future-proof PROMAS ST process control system completely automates animal feed and food industry factories. Remote support with on-line diagnostics and a 24-hour helpdesk are available to customers around the world.

Although many of our products are standard, all our systems can be optimized to your requirements with different options and modifications.

KSE Process Technology B.V.
Rondweg 27
5531 AJ BLADEL
The Netherlands

Tel. +31 (0)497 38 38 18
info@kse.nl

www.ALFRA.nl



Scan the QR code to
see the BUVM in action