

Twin-screw
extrusion system
CompacTwin™

CompacTwin™ – the flexible twin-screw extruder. Economical solution for numerous industries.

CompacTwin™ with attached single-stage preconditioner.

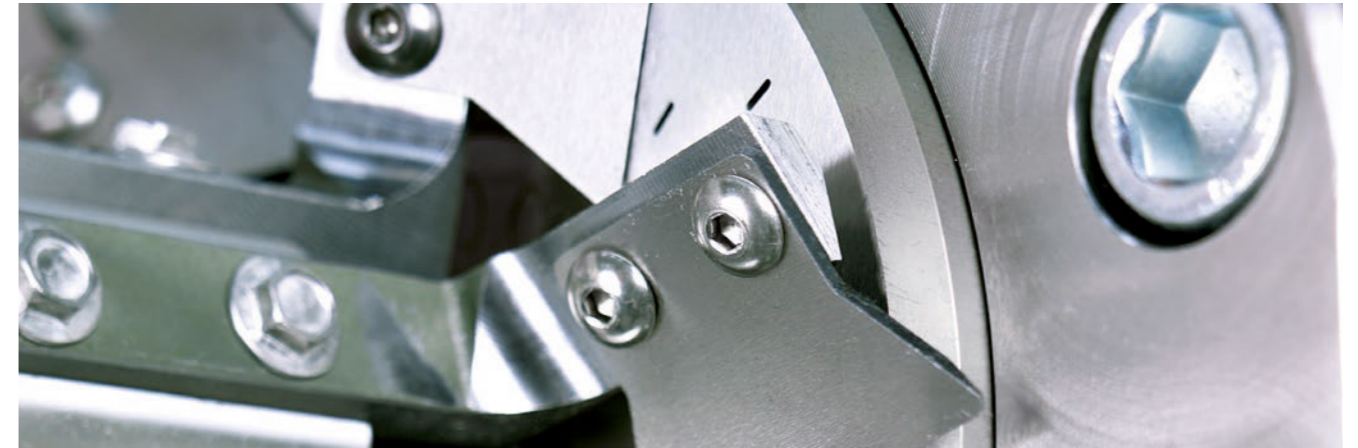
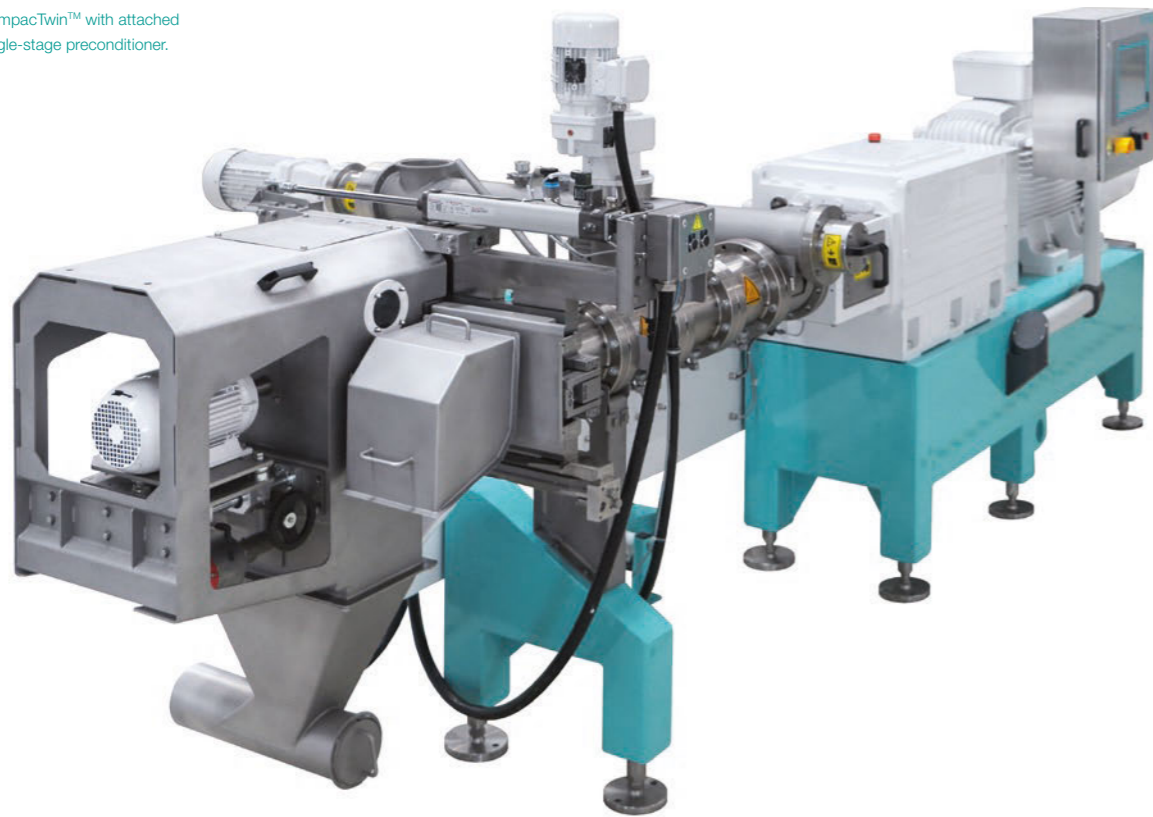

The cutting apparatus moves laterally to allow exchange of the knife head even during production.

Application examples:



Petfood:

- Direct-expanded kibbles
- Semi-moist pet food
- Foods for small pets
- Multicolor



Aquafeed:

- Micropellets
- Floating feeds
- Sinking feeds
- Shrimp pellets



Ready-to-eat:

- Direct expanded cereals
- Indirect expanded flakes



Standard ingredients:

- Modified flours and starches
- Breadcrumbs
- Texturized proteins
- Reconstituted rice
- Fortified rice



Indian snacks:

- 2D Snack pellets
- Direct expanded snacks

CompacTwin™ – wide range of applications.

The twin-screw extruder has been designed for a wide variety of applications in many different industries. The system ensures easy and reliable production of breakfast cereals, snacks, food ingredients, high-quality pet foods, and a number of other products, like fishfeed.

The CompacTwin™ is based on proven Bühler extrusion technology. It incorporates newly developed components as well as existing elements from proven machine series. The extruder has been designed for a maximum process pressure of 150 bar and a temperature of 250 °C.

The extruder is available in three sizes: 62, 93 and 125 mm screw diameter with a throughput capacity up to 3000 kg/h for food applications and 8000 kg/h for feed applications. The modular design and the lean concept of the system enable particularly easy operation and maintenance in addition to highly sanitary operation.

The lean design of the CompacTwin™ is especially suitable for trouble-free production of high volumes of a given product and product formula. The functional control system of the extrusion system allows dependable production and enables easy selection of the production parameters of the feeder, preconditioner, and extruder.

Design allowing flexible expansion.

The proven cutter, which can be moved to the side, enables the operator to exchange the knife head even during ongoing operation, which ensures a consistently high quality of the end products. The attachable hydraulic screw extraction device allows smooth removal of the shafts.

The barrel is newly designed. As a standard, the two-piece barrel is with tempering bores and with a nickel plated housing. The barrel of the process unit will be heated or cooled by a separate temperature control unit.

Depending on the application there is a choice between a single- or a double-stage preconditioner.

Various additional accessories available:

- Oil addition systems
- Forced feeding
- Venting spouts
- Density control units, especially for aquafeed
- Slurry systems

Modular technology ensures success. Performance features at a glance.

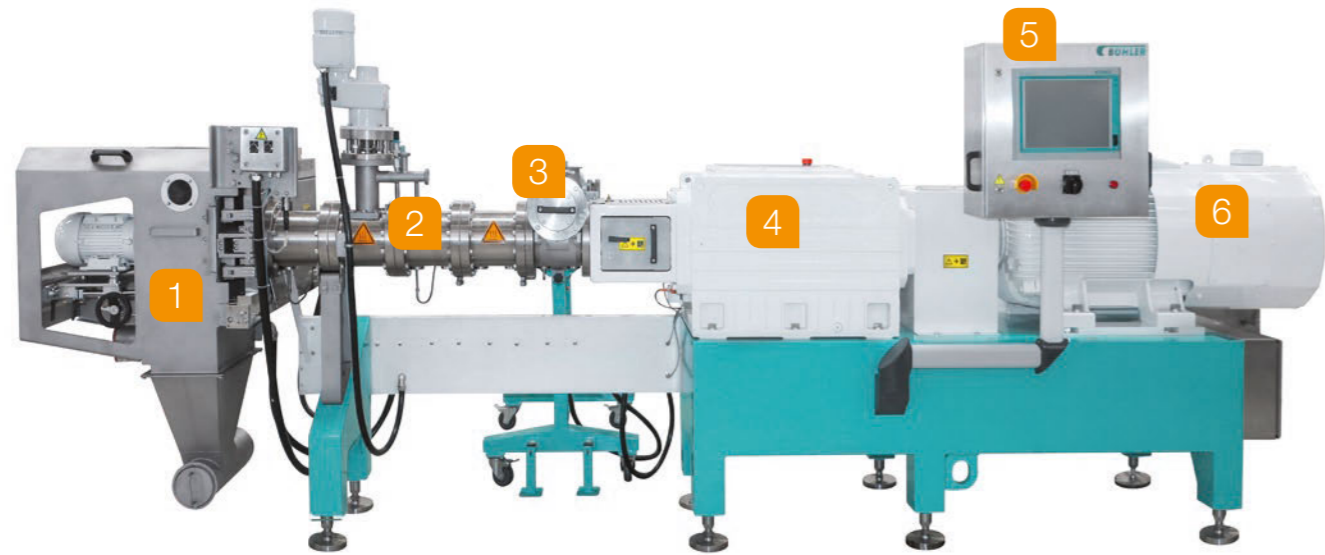

- 1** Proven cutter design which can be moved to the side: the cutter knives can be adjusted even during production. This prevents deformation of the extruded products as a result of inaccurate knife settings.
- 2** Process pressure of 150 bar and temperature of 250 °C.
- 3** The separate single-stage preconditioner can be detached from the extruder. Alternatively, a double-stage preconditioner is available.
- 4** Compact design of gearbox
- 5** Movable and intuitive control unit
- 6** Variable speed drive

User-friendly automation system for efficient and safe production.

The CompacTwin™ is equipped with a user-friendly and intuitive touch-screen control system. Safety circuits prevent damage due to improper use. Emergency situations will lead to fully automatic selfstopping of the extruder.

Customer benefits:

- Dependable production and fast selection of recipes or processing parameters for feeder, preconditioner and extruder
- Quick and easy operation of extruder which leads to constant and reproducible quality of the end product



Single-stage preconditioner mounted on movable base.



No scrapers are needed.

Single-stage preconditioner.

The newly developed single-stage preconditioner is a hygienic and economical solution designed for processes which do not require long retention times in the preconditioner. It is the ideal solution for fast and efficient moistening and heating of the raw material.

Inside the preconditioner, the raw material is fluidised and uniformly mixed with steam or added liquids. A new configuration of the preconditioner relative to the extruder eliminates the need for an additional transition between the two machines. The preconditioned product is fed directly into the extruder.

The system is mounted on a separate, traveling base and can be quickly and easily attached to the extruder. It is connected to the control system and the power supply through a plug-in coupling. This user-friendly concept allows the preconditioner to be detached without effort from the extruder for cleaning. The shaft of the preconditioner can easily be extracted from the tube.

Double-stage preconditioner.

The double-stage preconditioner provides a separation of the mixing zone from the retention zone. This ensures optimal, intensive mixing at high screw speeds and gentle retention across a narrow time range at a low screw speed.

The overlapping flight geometry configuration in the mixing zone as well as in the retention zone ensures thorough scraping of all internal surfaces in contact with the product. Beside allowing a very narrow retention (dwell) time range, it also enables complete emptying of the preconditioner after production.

The design of the double-stage preconditioner is such that the material inlet is vertically positioned exactly above the outlet. A large number of connections for supplying steam and adding liquids are available in the mixing zone. The machine is installed on the supports provided at both ends.



Preconditioning system with outstanding sanitation and accessibility thanks to large doors.

Service for demanding customers. **Available worldwide, reliable and fast.**

Customers can rely on Bühler when it comes to service and maintenance of their extrusion systems. Thanks to company representatives the world over, specialists are always within reach when needed. A central spare parts service also ensures that required components are always at the ready for fast shipment.



When customers need spare parts or support from a technician, Bühler stands ready.

Customized maintenance, retrofitting and reconditioning packages ensure that your Bühler equipment is always state of the art. The advantage: customers can operate profitably and reliably even with older systems. Training options tailored specifically to production personnel ensure smooth machine operation that results in excellent product quality with optimum throughput.

Bühler is represented on every continent, maintains its own production, development, and service locations worldwide, and is quickly on site when customers need good service.

Special service offerings like barrel wear measurement service enable optimum system output and training courses keep personnel abreast of current technologies and safety standards – for labor law regulations as well as food safety.

In our pilot plants in Switzerland, China and the USA customers can conduct trials on standard machines and can learn about the possibilities of extrusion.

Technical data. **CompacTwin™.**

Technical data:

Extruder with process length 20D		CompacTwin™ 62	CompacTwin™ 93	CompacTwin™ 125
A	mm	4618	6282	7812
B	mm	1240	1860	2501
Extruder screw diameter	mm	62	93	125
Throughput subject to product	kg/h	max. 1000	max. 4000	max. 8000
Maximum electric power	kW	max. 132	max. 250	max. 450

The CompacTwin™ is available with several process lengths.
 All data are approximate values. Subject to technical changes without notice.

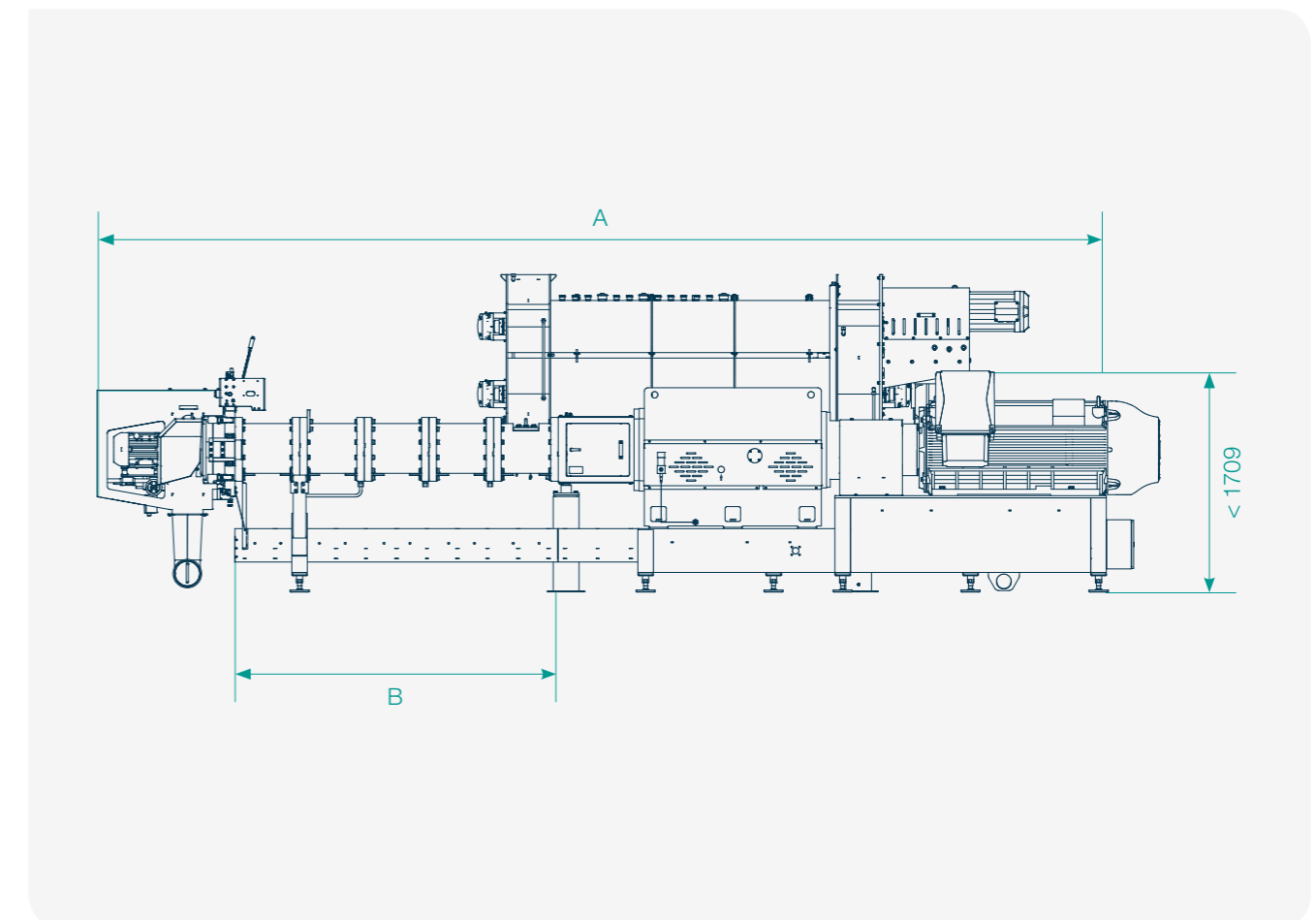

Bühler AG

CH-9240 Uzwil
Switzerland

T +41 71 955 11 11
F +41 71 955 66 11

buhlergroup.com

Flyer CompactTwin™ en 04/17 ZACC