

MODERN PROCESS EQUIPMENT CORPORATION

CHAIN-VEY

**THE BETTER
WAY TO CONVEY**



www.CHAINVEY.com

+1.773.254.3929 • SOLUTION@CHAINVEY.COM



THE MOST GENTLE & EFFICIENT

TRANSPORT AVAILABLE FOR VIRTUALLY ANY PRODUCT

ROTARY DISCHARGE VALVE

Pneumatically actuated rotary valve allows for unobstructed product discharge

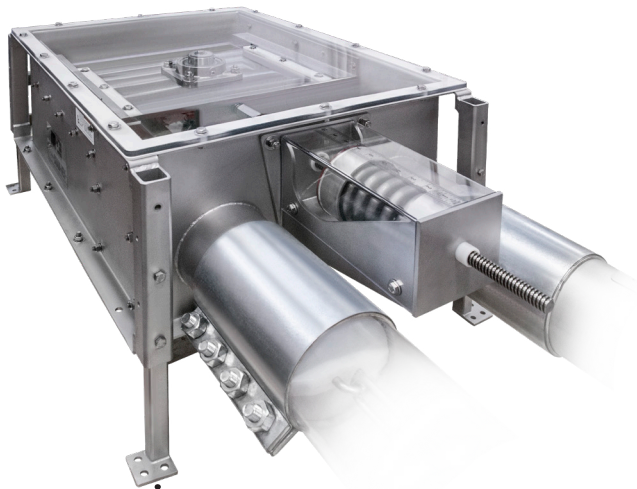
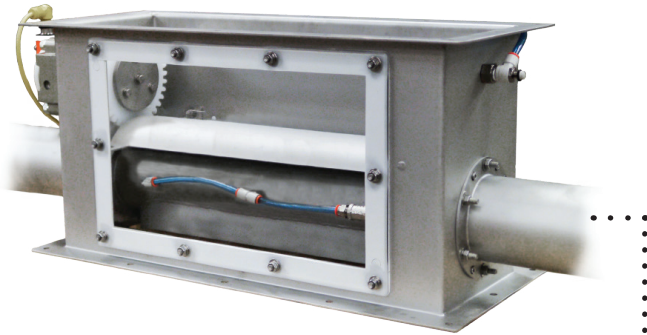

180° TURNAROUND

PRODUCT INLET

With optional flow baffle

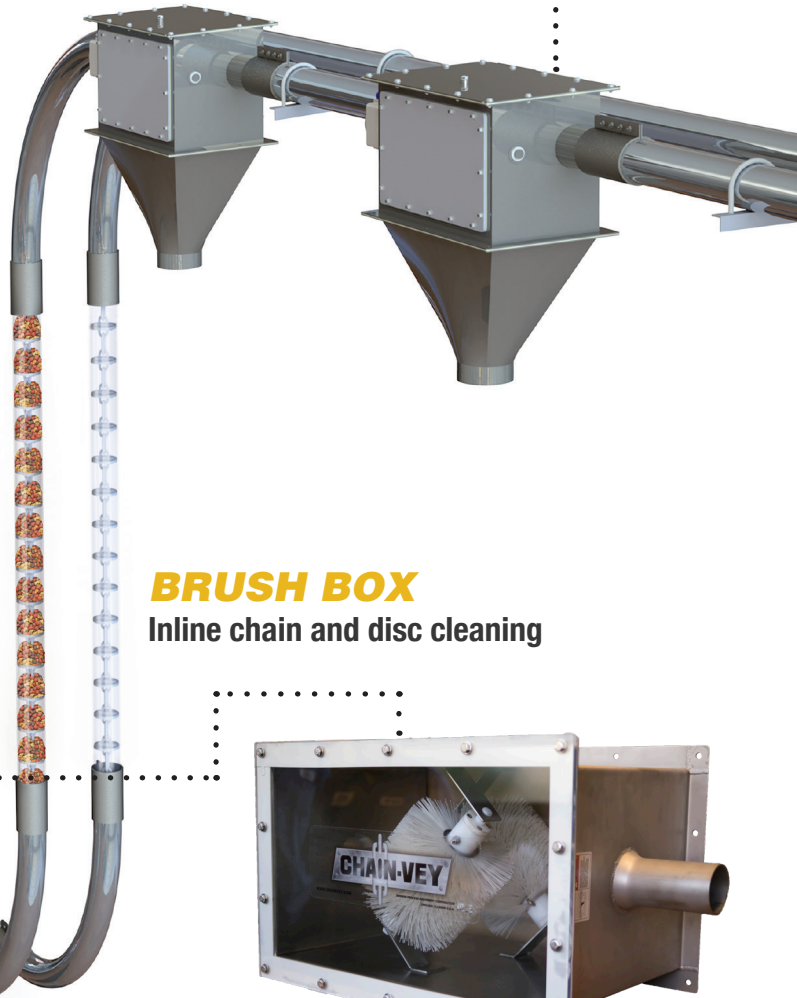
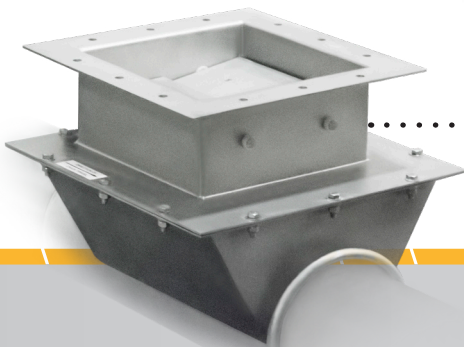

BRUSH BOX

Inline chain and disc cleaning

DISC MATERIALS AND PERFORMANCE

- FDA approved UHMW discs
- Disc design options include direct over-molded onto stainless steel chain or split design with sanitary stainless steel compression rivet fastener
- Chain available in 301 stainless steel or ultra high strength hardened carbon alloy steel
- All chain has ultimate tensile strength of over 16,000 lbs.

180° DRIVE UNIT

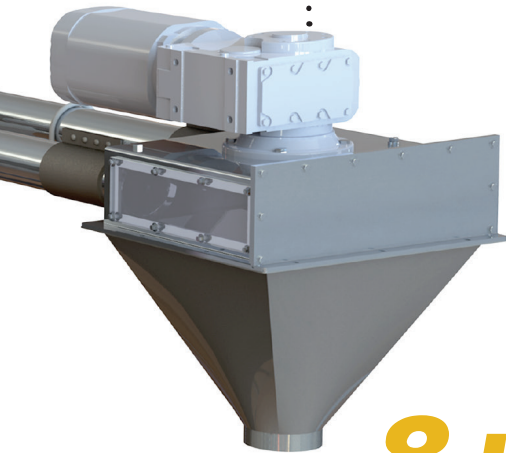

CHOOSE YOUR CONVEYING

CAPACITY

8 IN. 2,000 ft³/hr (56 m³/hr) **6 IN.** 1,400 ft³/hr (40 m³/hr) **5 IN.** 1,000 ft³/hr (28 m³/hr) **4 IN.** 650 ft³/hr (18 m³/hr) **3 IN.** 175 ft³/hr (5 m³/hr)

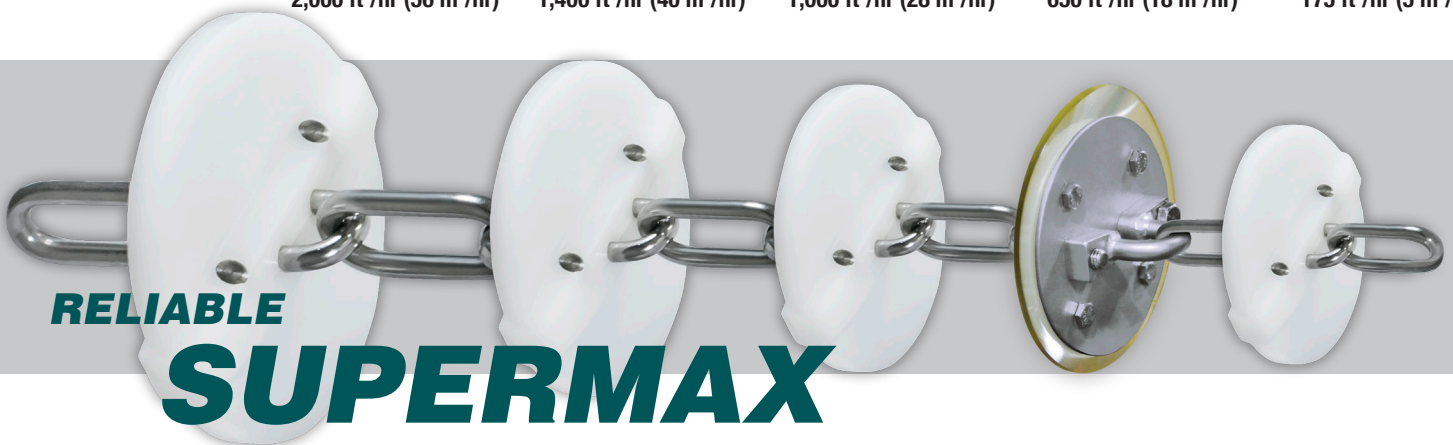

RELIABLE

SUPERMAX

CONNECTOR LINK SYSTEM

CHAIN-VEY®

A DIVISION OF MODERN PROCESS EQUIPMENT CORPORATION

3125 SOUTH KOLIN AVENUE • CHICAGO, ILLINOIS 60623 U.S.A.

TOTAL SYSTEM SOLUTIONS



AVAILABLE SYSTEM DESIGNS



CHAIN-VEY® DESIGN TYPE	CLEANING CAPABILITIES	DESIGN FEATURES & OPTIONS	AUXILIARY CLEANING EQUIPMENT & SERVICES
STANDARD	<ul style="list-style-type: none"> Ideal for Dry Products and Ingredient <1% Crossover Between Batches and/or Product Changeovers Eliminate Product Accumulation on Chain/Puck and Internal Components 	<ul style="list-style-type: none"> Polyurethane Wiper Disc Magnathane Wiper Disc Adjustable Air Knives 	<ul style="list-style-type: none"> Brush Box (Dynamic) Brush box (Static)
HYBRID CLEAN-IN-PLACE	<ul style="list-style-type: none"> Facilitates the introduction of Water, Foam and/or Dry Ice into System Permits Change in Flavor Profiles and Product Colors Changeover Between Product Varieties (i.e. gluten /non-gluten) Eliminate Allergens 	<ul style="list-style-type: none"> Modifications to Turnaround, Drive and Discharge Valves to Include Spray Nozzles, Drying Port and Drain Pan Cleanout Access Doors on Transitions, Turnaround and Drive Unit Drop-in Sponge Link Flange Pipe Connections Full CIP Turnaround and Drive Unit Design 	<ul style="list-style-type: none"> Standalone Foaming Unit and Dry Ice Blasting Unit Integration of Existing Plant CIP System/Practices Manifold Design to Facilitate Quick Connection Points Automated Drain and Drying Valves for Automated Cleaning Cycles Fully Automatic Mobile Cleaning Cart Facilitating Four Stage CIP Cycle: Rinse, Wash, Sanitize and Dry
CLEAN-IN-PLACE	<ul style="list-style-type: none"> Facilitates the introduction of Water, Foam and/or Dry Ice into System Permits Change in Strong Flavor Profiles and Product Colors Changeover Between Product Varieties (i.e. gluten /non-gluten) Passes All Swab Tests: ATP, Aerobic Plate Count, Coliform, Bi-Luminous 	<ul style="list-style-type: none"> Flanged Pipe Connections Allowing System to be Flooded Full CIP Turnaround & Drive Unit Design Including Elimination of Harborage Points, Spray Nozzles, Drying Ports and Drains Nitric Acid Passivation Pipe and Component Polish 	<ul style="list-style-type: none"> Integration of Existing Customer CIP System/Practices Manifold Design to Facilitate Quick Connection Points Automated Drain and Drying Valves for Automated Cleaning Cycles Fully Automated Mobile Cleaning Cart Facilitating Four Stage CIP Cycle: Rinse, Wash, Sanitize, Dry

COMPARE OUR SYSTEM →

LET US HELP

Ask about our free product testing

and system design capabilities. +1.773.254.3929 • SOLUTION@CHAINVEY.COM

THE MPE
CHAIN-VEY®
TUBULAR DRAG CONVEYOR

**CONVEYS PRODUCTS GENTLY,
EFFICIENTLY, HORIZONTALLY AND
VERTICALLY IN A DUST-TIGHT
ENVIRONMENT WITHOUT PRODUCT
DEGRADATION OR DECLASSIFICATION**

CHAIN-VEY® BENEFITS:

- ◆ **MINIMIZES PRODUCT BREAKAGE,
DEGRADATION AND DECLASSIFICATION
(SEGREGATION)**
- ◆ **FLEXIBLE: COMBINES HORIZONTAL AND
VERTICAL TRANSPORT IN ONE SYSTEM**
- ◆ **CIP (CLEAN-IN-PLACE) CAPABILITIES
FOR OPTIMUM SANITARY CONDITIONS**
- ◆ **ENERGY EFFICIENT**

SUPERIOR CONVEYING



CHAIN-VEY® VS. OTHER CONVEYING METHODS

CONVEYOR DESIGN FEATURES							
CONVEYOR METHODS	MAINTAINS PARTICLE DISTRIBUTION (INTEGRITY)	AIR / DUST TIGHT	CLEAN-IN-PLACE (CIP)	ENERGY EFFICIENT	EXTENDED LENGTH CAPABILITY	LOW / NO MAINTENANCE	MULTIPLE INLETS / DISCHARGES
CHAIN-VEY®	✓	✓	✓	✓	✓	✓	✓
AUGER/ELEVATOR						✓	
BUCKET ELEVATOR	✓			✓			✓
DENSE PNEUMATIC		✓			✓		✓
DILUTE PNEUMATIC		✓			✓		✓

TYPICAL CHAIN-VEY® APPLICATIONS

FOOD

Barley
Bread Crumbs
Brown Sugar
Cereal
Cheese Powders

Cocoa
Coffee: Green
Coffee: Ground
Coffee: Roasted
Coffee: Whole Bean

Cookie Crumbs
Crackers
Flour: Corn
Flour: Wheat

Fruit: Dried
Fruit: Frozen
Hard Candy
Hops
Ingredients

Jelly Beans
Krill Oil
Malt / Meal
Oats: Rolled
Oats: Instant

Oats: Steel Cut
Pepper
Rice: Dried
Rice: Puffed
Snack Foods

Soluble Corn Fiber
Soup Mix
Spices
Tea
Vegetables: Frozen

Vitamins: Powdered
Wheat

BEANS / NUTS / SEEDS

Almonds
Black Beans
Cocoa Beans

Grains / Seeds
Great Northern Beans
Kidney Beans

Lentils
Lima Beans
Navy Beans

Oil Seeds
Pecans
Peanuts: Blanched

Peanuts: Roasted
Pinto Beans
Soy Beans

Walnuts

PET FOOD

Chicken Meal
Dry Food
Fines / Add backs

Fish Food
Fish Meal
Horse Feed

Raw Ingredients
Treats
Whole Kibble

CHEMICAL

Biomass (Torrefied)
Calcium Carbonate
Calcium Hydrate

Coke
Detergent
Feed Phosphate

Fertilizer
Flake Resin
Pesticide

Sodium Bicarbonate

MINERAL

Activated Carbon
Activated Coal Ash
Alumina Hydrate

Ash
Bentonite Clay
Carbonate

Clay
Coal
Coal: Brown

Coal: Dry
Graphite
Limestone

Sintered Dust
Talcum Powder

OTHER

Latex
Litter
Pellets

Pigments
Plastics
Sawdust

Shredded Waste
Tobacco
Wax Flakes

Wood Chips

DON'T SEE YOUR SPECIFIC APPLICATION?

Contact a MPE Sales Engineer in order to set up product feasibility testing at our Full Scale Chain-Vey Lab located in Chicago, IL, U.S.A.

CHAIN-VEY®

A DIVISION OF MODERN PROCESS EQUIPMENT CORPORATION

3125 SOUTH KOLIN AVENUE • CHICAGO, ILLINOIS 60623 U.S.A.

WWW.CHAINVEY.COM • E: SOLUTION@CHAINVEY.COM • P: +1.773.254.3929 • F: +1.773.254.3935