

AIRMATIC®

WE'LL HANDLE IT.

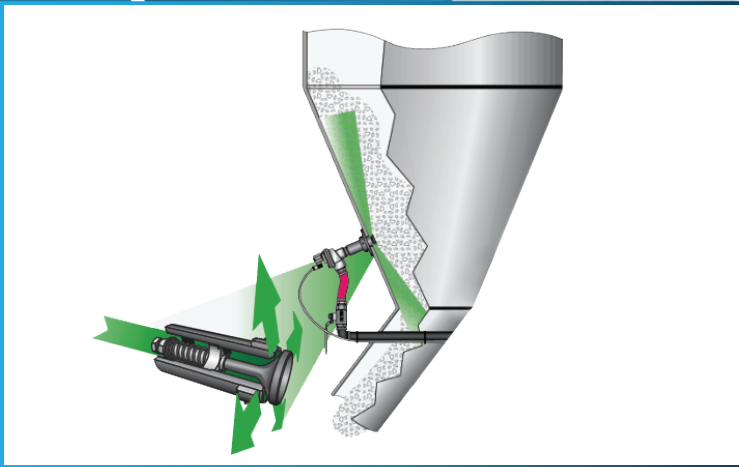

WORKMASTER®
WE FIND A WAY — OR MAKE ONE!

BIN-BUTLER®

Aeration System

AIRMATIC

284 Three Tun Rd. Malvern, PA 19355

215.333.5600

infocenter@airmatic.com

airmatic.com

FORMULA FOR SUCCESS

The BIN-BUTLER Aeration System is a cost effective solution for prompting and maintaining the flow of a variety of powders and bulk solids. The System's Injector Heads fire a radial pattern of powerful air pulses between the material and the container wall to undercut, excite, and put the material in fast motion. The dislodged, stimulated material then flows downward to the outlet. Our solid-state, Programmable Time-Sequence Controller is used to precisely fire the System's strategically located Injector Heads so that they act in concert to maintain a consistent, regulated outflow during the storage vessel's discharge cycle.

DOLLAR SMART

The BIN-BUTLER Aeration System is quiet, long-lasting, and energy efficient. The average system uses less than 10-CFM of plant air — significantly less than other types of aerators (ie, air pads, activators, disk/jet type fluidizers), air cannons, lances, or pneumatic vibrators. Because there's no induced vibration, the BIN-BUTLER System won't fatigue storage vessel walls. And, since the System can be mounted from outside the container, the installation is simple and fast so as to minimize labor and downtime costs.

- ▶ **RESTORES 100% CAPACITY**
- ▶ **NON-DAMAGING TO VESSEL**
- ▶ **FAST, SIMPLE INSTALLATION**
- ▶ **WON'T JAM OR CLOG**
- ▶ **MOUNTS TO ANY STRUCTURE OR SURFACE**
- ▶ **INJECTOR HEAD WARRANTY — 1 MILLION CYCLES!**

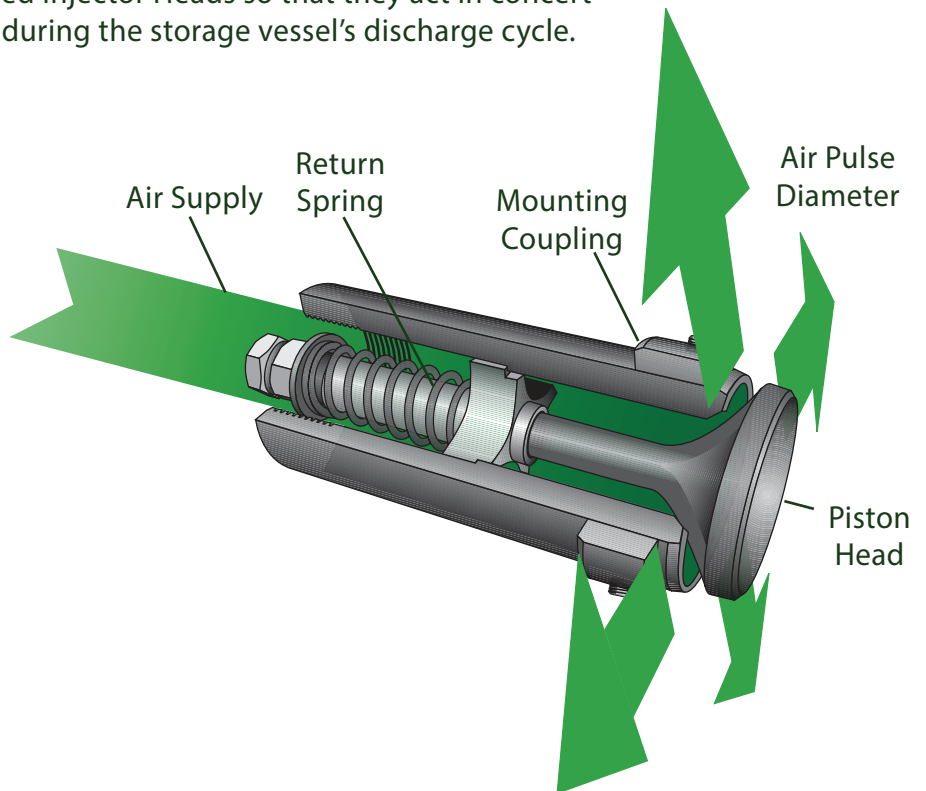

PERFORMANCE DATA

MODEL#	MATERIAL	MOUNT	DISCHARGE (in)
BB-075	Carbon or Stainless	Coupling	3/4
BB-200	Carbon or Stainless	Coupling or Flange	2

AIR PRESSURE (PSI)		AREA OF INFLUENCE (Dia in Ft)		AIR CONSUMPTION (CFM)*	
40	60	2	3	0.3	0.5
80	100	4	5	0.7	0.9
40	60	2	4	0.6	1.2
80	100	6	8	1.8	2.4

*CFM Measured at one PPM (Pulse per Minute)

VERSATILE

The BIN-BUTLER Aeration System will instantly induce, and then maintain the flow of a diverse scope of materials encompassing a broad range of bulk density, size, flowability, abrasiveness, and other powder and bulk solids characteristics. We've solved flow problems from metal, concrete, wood and fiberglass bins, hoppers, and silos; through chutes, batchers, conveyor transfer points, ducts, channels, railcars, screens, and feeders. In addition to standard applications, the BIN-BUTLER System can also be used to aid material flow in enclosed chutes, and pneumatic conveying systems. It acts directly on the stored material (not the structure) to eliminate arching, bridging, clinging, piping, and other flow problems. It restores 100% bin capacity and ensures the FIFO free flow of even the most stubborn materials. And, when supplied with clean, dry compressed air (or nitrogen) the BIN-BUTLER System will operate at pressures ranging from 40 - 125 PSI, and in temperatures up to 550° F.

Applications

Adipic Acid; Bentonite; Cement; Diatomaceous Earth; E.P. Dust; Flour; Grain; Herbicides; Iron Ore; Jute Products; Kaolin; Limestone; Meal; Nuts & Seeds; Ore Preparations; Pharmaceuticals; Quartz; Resin; Salt; Titanium Dioxide; Uranium; Verniculite; Walnut Shells; Xanthene Dyes; Yellow Pine Chips; Zinc Oxides.

BIN-CHARTING

The determination of model, quantity, and area-of-influence of each Injector Head's air pulse is dependent on the geometry of the storage vessel, the stored material's properties and characteristics, the current flow pattern, and the desired outcome. To regain 100% bin capacity, or achieve metered discharge rates, the BIN-BUTLER Injector Heads need to be sized and positioned correctly, the application's air supply needs to be analyzed, and the time-sequence firing pattern determined.

- ▶ **INSTANT, CONTROLLED "FIFO" FLOW**
- ▶ **OPERATING PRESSURE 40 PSI - 125 PSI**
- ▶ **OPERATES IN TEMPERATURES TO 550°F**
- ▶ **HEAVY-DUTY, DURABLE, MAINTENANCE-FREE**
- ▶ **AVAILABLE IN CARBON OR STAINLESS STEEL**

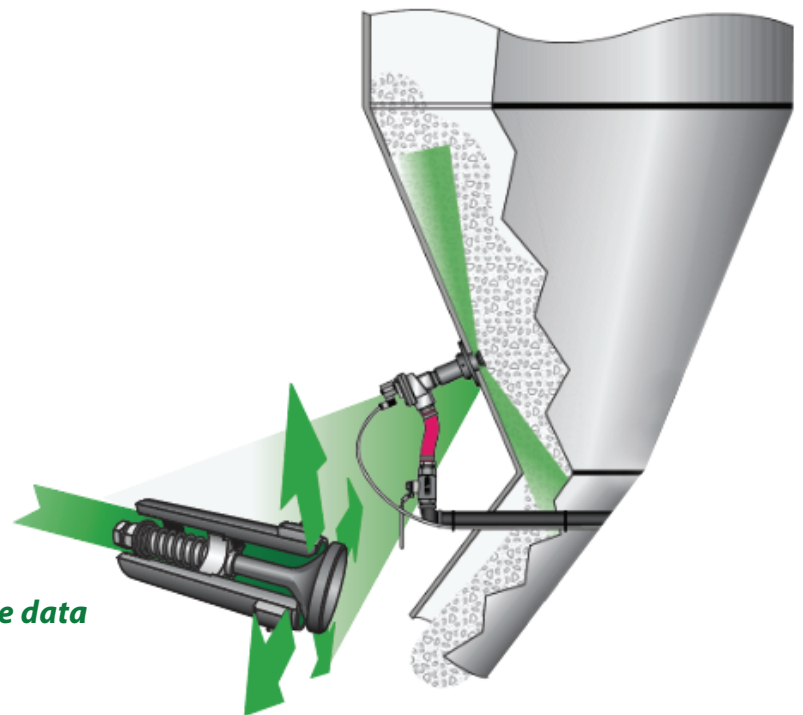

For a FREE, no obligation custom proposal, send us the data sheet specifics of your application!

AIRMATIC®

WE'LL HANDLE IT.

AIRMATIC founded in 1944, is a woman-owned Industrial Distributor, with installation and maintenance capabilities, offering equipment, machinery, and shop supplies to the Industrial, Construction, Utility, Government, and Commercial Markets. Our products and services are sold through three business units:

The **MATERIALS MANAGEMENT GROUP** provides products and services to industries that convey, store, transport, and process powders and bulk solids from aggregates, cement, and chemicals to foods, grains, metals, power generation, and waste water treatment applications;

The **SERVICE GROUP** provides fabrication, installation, and maintenance services to improve bulk materials handling efficiency; mechanical clean-out services for silos and hoppers to eliminate material flow problems; and shop repair/rebuilding and modifications services of products sold by the Company.

The **TOOL GROUP** provides power tools, personal protective equipment, materials-handling equipment, shop equipment and MRO supplies used for production, fabrication, assembly, metal removal, maintenance, and storage in manufacturing, construction, utility, and commercial applications.

Our Customers tell us that by choosing AIRMATIC to solve their problems, they gain increased productivity, decreased costs, and a safer, cleaner work environment.

WORKMASTER

WE FIND A WAY — OR MAKE ONE!

WORKMASTER specializes in manufacturing labor-saving bulk material handling tools designed to facilitate the safe and efficient unloading, transport, storage, and processing of bulk solids. Catering to the needs of the agriculture, manufacturing, mining, and concrete construction sectors, **WORKMASTER** provides a distinctive line of bulk solids handling equipment. Our innovative products empower plant workers to safely accomplish tasks effortlessly and swiftly such as opening and unloading hopper bottom railcars and dry bulk trailers, ensuring the smooth flow of material from bins and silos, and improving the consolidation and finishing of freshly poured concrete through form, table, and surface vibration techniques. Our products play a pivotal role in enhancing safety and efficiency for our customers, while also extending the lifespan of critical production equipment. By reducing operating and maintenance costs, our tools prove invaluable for tackling some of the industry's most hazardous, challenging, and demanding tasks.

AIRMATIC

284 Three Tun Rd. Malvern, PA 19355

215.333.5600

infocenter@airmatic.com

airmatic.com